



# **Vision Sensor (SS4000)**

## **User Manual**








# Foreword

## Overview

This manual introduces the configurations and operations of SS4000 vision sensor (hereinafter referred to as the “the sensor”). Read carefully before using the device, and keep the manual safe for future reference.

## Safety Instructions

Table 1-1 Signal Description

Signal	Description
 DANGER	Indicates a high potential hazard which, if not avoided, will result in death or serious injury.
 WARNING	Indicates a medium or low potential hazard which, if not avoided, could result in slight or moderate injury.
	Indicates a potential risk which, if not avoided, could result in property damage, data loss, lower performance, or unpredictable result.
	Provides methods to help you solve a problem or save your time.
	Provides additional information as a supplement to the text.

## Revision History

Table 1-2 Revision History

Version Number	Content	Release Date
V1.0.0	First release.	Jun. 2025

# Important Safeguards and Warnings

This section introduces content covering the proper handling of the device, hazard prevention, and prevention of property damage. Read carefully before using the device, and comply with the guidelines when using it.

## Operation Requirements

- Do not install or place the device in a location that exposes it to sunlight or heat sources.
- Keep the device away from dampness, dust or soot.
- Install the switch horizontally on a stable surface to prevent it from falling.
- Do not drop or splash liquid onto the product, and make sure that there is no object filled with liquid on the product to prevent liquid from flowing into the product.
- Put the device in a well-ventilated place, and do not block its ventilation.
- Operate the device within the rated range of power input and output.
- Do not disassemble the device without professional instruction.
- Transport, use and store the device under allowed humidity and temperature conditions.
- Connect the Device (type-I structure) to the power socket with protective earthing.

## Power Requirement

- Use the recommended power cables in the region and conform to the rated power specification.
- Use the standard power adapter. Otherwise, it might result in personal injury and device damage.
- The power source shall conform to the requirement of the Safety Extra Low Voltage (SELV) standard, and supply power with rated voltage which conforms to Limited power Source requirement according to IEC60950-1. Please note that the power supply requirement is subject to the device label.
- Connect the Device (type-I structure) to the power socket with protective earthing.

# Table of Contents

Foreword.....	I
Important Safeguards and Warnings.....	II
1 Introduction.....	1
1.1 Overview.....	1
1.2 Features.....	1
1.3 Appearance and Interface.....	1
1.3.1 Dimension.....	1
1.3.2 Appearance.....	2
1.3.3 Interface.....	4
2 Electrical Specifications.....	7
2.1 Power Supply and Network Ports.....	7
2.2 I/O Ports.....	7
2.2.1 Opto-isolated Input.....	7
2.2.2 Opto-isolated Output.....	9
2.3 External I/O Wiring.....	11
2.3.1 Opto-isolated Input.....	11
2.3.2 Opto-isolator Output.....	13
2.4 How to Avoid EMI and ESD.....	15
3 Installation.....	16
3.1 Precautions.....	16
3.1.1 Safety Requirements.....	16
3.1.2 Heat Dissipation Requirements.....	16
3.2 Hardware Installation.....	17
3.2.1 Packing List.....	17
3.2.2 Accessories and Installation.....	17
3.3 Network Settings.....	18
4 Client Software.....	21
4.1 Desktop Client.....	21
4.1.1 Configuration Requirement.....	21
4.1.2 Install Client.....	21
4.1.3 Uninstall Client.....	24
4.1.4 Client Operations.....	26
4.1.5 Image Save.....	33
4.2 Web Client.....	35
4.2.1 Compatibility Requirement.....	35
4.2.2 Web Client Operation.....	35
5 Client Software Layout.....	37

5.1	Main Control.....	37
5.2	Image Review.....	39
5.3	User Management.....	40
5.4	Language.....	41
5.5	Restart and Logout.....	42
6	Set Project.....	43
6.1	Shooting Setup.....	44
6.2	Master Registration.....	48
6.3	Algorithm Setup.....	49
6.4	I/O and Communication Setup.....	51
6.4.1	I/O Setup.....	51
6.4.2	Communication Setup.....	53
7	Project Management.....	55
8	Device Management.....	58
8.1	Time Calibration.....	58
8.2	Maintenance.....	58
8.3	Firmware Upgrade.....	59
8.4	Network.....	59
8.5	Log.....	59
8.6	About.....	60
9	Operator Tools.....	61
9.1	Location Tools.....	61
9.2	AI Tools.....	65
9.3	Exist Tools.....	68
9.3.1	Find Line.....	68
9.3.2	Find Circle.....	70
9.3.3	Blob Exist.....	72
9.4	Count Tools.....	73
9.5	Measure Tools.....	75
9.5.1	Grayscale Area.....	75
9.5.2	Brightness.....	77
9.5.3	Contrast.....	78
9.5.4	Edge Width Tool.....	79
9.6	Detection Tools.....	82
9.7	Recognition Tools.....	85
9.7.1	Data Code.....	85
9.7.2	Barcode.....	86
9.7.3	OCR (Optical Character Recognition).....	88
9.7.4	Color Recognition.....	94
9.8	Logic Tools.....	97

9.8.1 Logic Check.....	98
9.8.2 Condition Check.....	99
9.8.3 Mathematical.....	100
9.8.4 String Comparison.....	101
10 Communication Protocol Document.....	103
11 FAQ.....	104
11.1 Client Cannot Find Sesnsor.....	104
11.2 Sensor Disconnection.....	104
11.3 Algorithm Processing Does Not Meet Expectations.....	104
11.4 External Trigger Cannot be Enabled.....	104
11.5 Unable to Login the Web Client.....	105

# 1 Introduction

## 1.1 Overview

The SS4000 vision sensor features lightweight and versatility, and the users can freely configure its algorithms. The sensor has excellent imaging capabilities adopting the new optical design. As for the client software EasyVS, it supports the web-based access to provide a more convenient operation experience. Besides, many algorithm tools are supported in the vision sensor, such as AI learning, positioning, detection, recognition, etc. Many industrial communication protocols supported in the vision sensor ensure that the requirements of data transmission in the most industrial applications are met so that the sensor can still work stably in the complex industrial environments. The SS4000 vision sensor can be applied in various industries, such as consumer goods manufacturing, medical device manufacturing, food manufacturing, packaging material manufacturing, electronics manufacturing, etc.

## 1.2 Features

- Supports the web client.
- Supports multiple operator tools, such as AI classification, code reading, feature finding, and feature matching, etc.
- Supports the auto-focus mode.
- Supports multiple ports, such as IO port, Ethernet port, RS-232 port and GPIO port, and multiple communication protocols.
- Adopts an industrial-grade 100M Ethernet interface, with IP65 protection.

## 1.3 Appearance and Interface

### 1.3.1 Dimension

The dimensions of the SS4000 vision sensor are shown in the figures below.

Figure 1-1 Dimensions in Non-twist Status

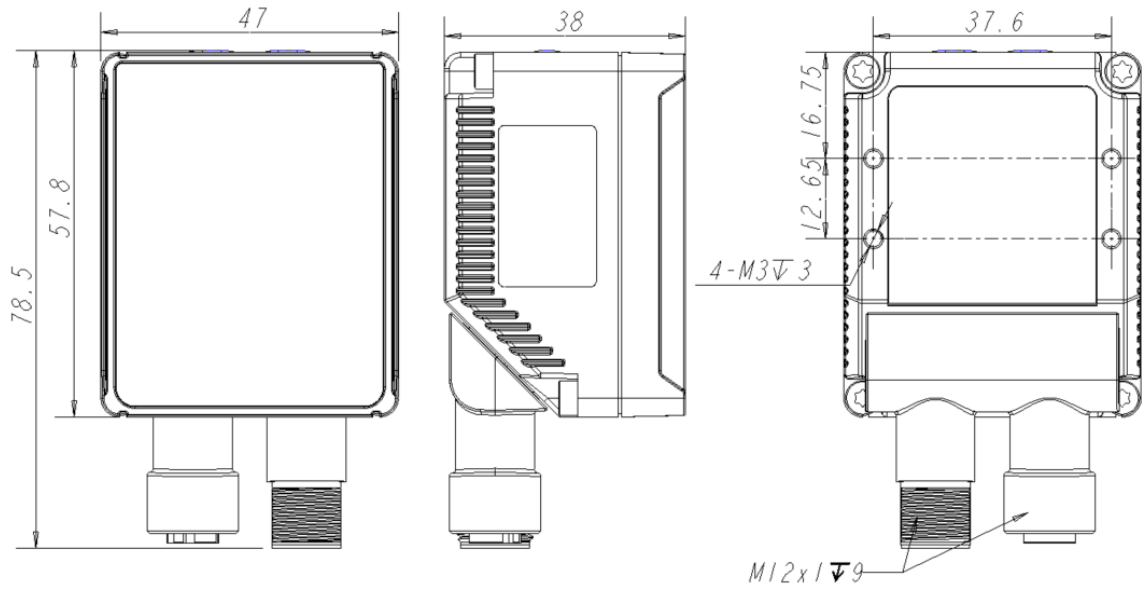
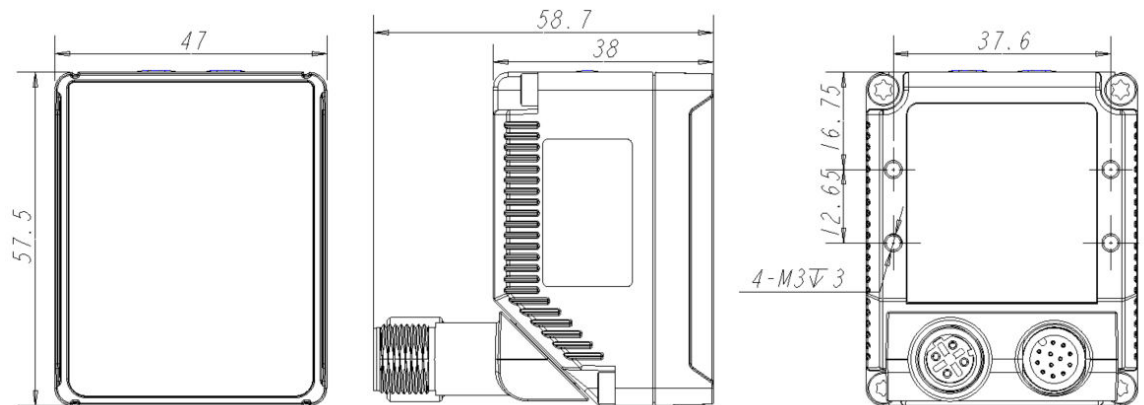


Figure 1-2 Dimensions in Twisted Status



### 1.3.2 Appearance

The appearance diagram of SS4000 vision sensor is as follows.

Figure 1-3 Appearance Diagram

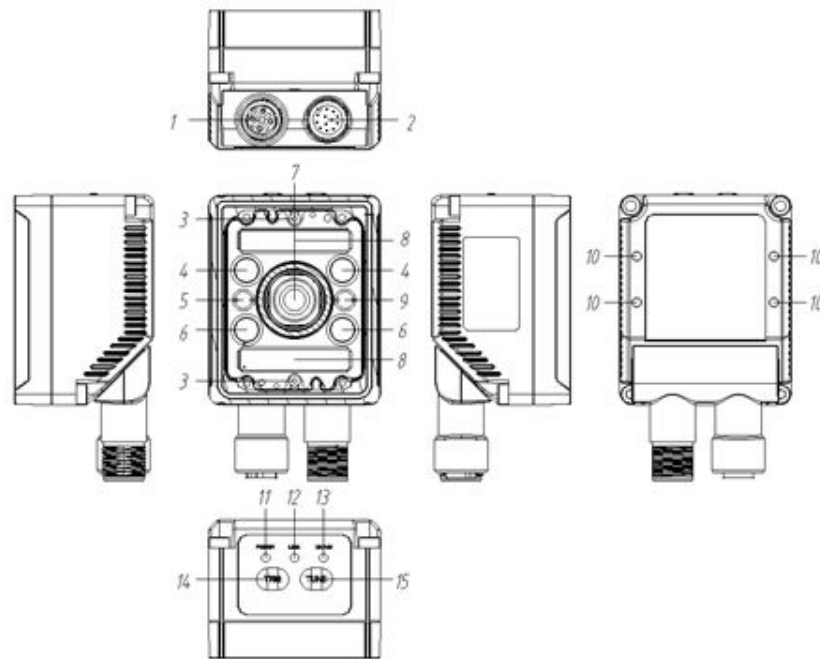


Table 1-1 Device Description

No.	Item	Description
1	Network Port	4-Core 100M network port
2	Power Supply Port	12-Core I/O ports, including power supply, I/O port, RS-232, etc.
3	Laser Aimer	For positioning and commissioning.
4	Light Source	Polarized/Non-polarized light sources. User can enable or disable the lighting function.
5	Red Dot Indicator	When the project is NG, the indicator is solid for 500ms.
6	Light Source	Polarized/Non-polarized light sources. User can enable or disable the lighting function.
7	Sensor	For acquiring images.
8	Diffuse Light Source	User can enable or disable the lighting function.
9	Green Dot Indicator	When the project is OK, the indicator is solid for 500ms.
10	Screw Hole	Use the M3 screws packed in the package to fix the device.

No.	Item	Description
11	POWER Indicator	Power indicator will be solid green after power supply port is connected normally.
12	LINK Indicator	The network indicator is solid green after the network is connected normally and flashing green when performing the data transmission.
13	OK/NG Indicator	It is solid green when the project is OK; it is solid red when the project is NG.
14	TRIG Button	When the trigger mode is set to serial mode or Ethernet mode, user can press the button to trigger the image acquiring function.
15	TUNE Button	Long press the button for 3 seconds, quickly press the button once after hearing the beep sound, and the sensor will perform smart adjustment of image parameters.

### 1.3.3 Interface

- 4-Core: M12 D-CODE female receptacle, including 100M network port.
- 12-Core: M12 A-CODE male port, including power supply port, I/O trigger ports, and RS-232 serial port.

Figure 1-4 4-Core and 12-Core Ports

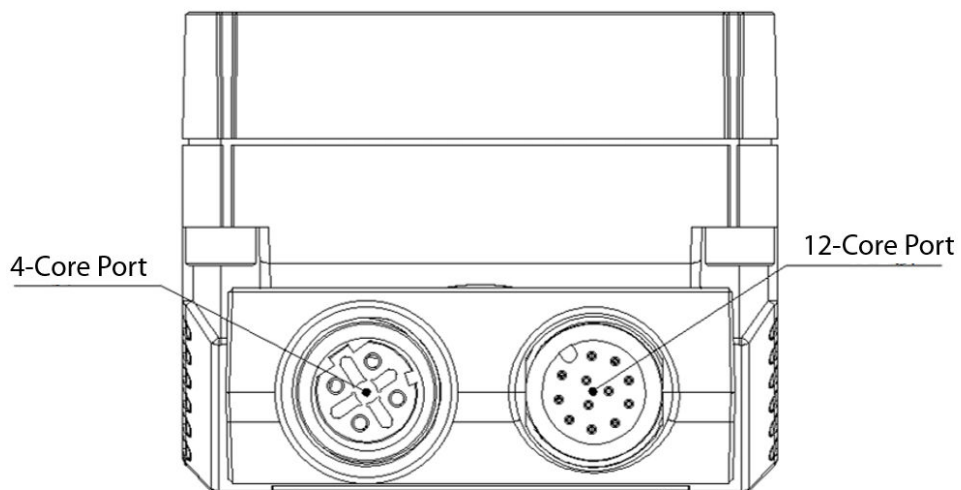


Figure 1-5 Pins of 12-Core Port

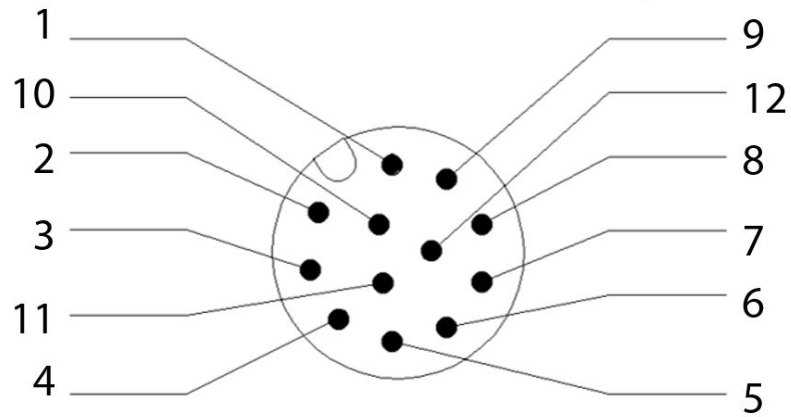


Table 1-2 Definitions Description

Pin	Signal	Description	Recommend Cable Description	Color
1	OPT_OUT2	Opto-isolated output 2	Brown-White scattered wire	Brown-White
2	RS232_TXD	RS-232 serial port for sending	DB9 female serial port	Grey
3	RS232_RXD	RS-232 serial port for receiving	DB9 female serial port	Purple
4	SIGNAL_GND	RS-232 serial port GND	DB9 female serial port	Black-White (casing)
5	OPT_IN1	Opto-isolated input 1	-	Yellow
6	OPT_IN_GND	Opto-isolated input GND	Purple-White scattered wire	Purple-White
7	POWER	Sensor power	DC 5.5 female receptacle	Red
8	POWER_GND	Sensor Power Ground	DC 5.5 female receptacle	Black
9	OPT_OUT_GND	Opto-isolated output GND	-	Green
10	OPT_IN0	Opto-isolated input 0	Orange scattered wire	Orange
11	OPT_OUT0	Opto-isolated output 0	-	Blue
12	OPT_OUT1	Opto-isolated output 1	-	Brown
—	—	Shielding GND	—	White (casing)

Figure 1-6 Recommend Cable Diagram

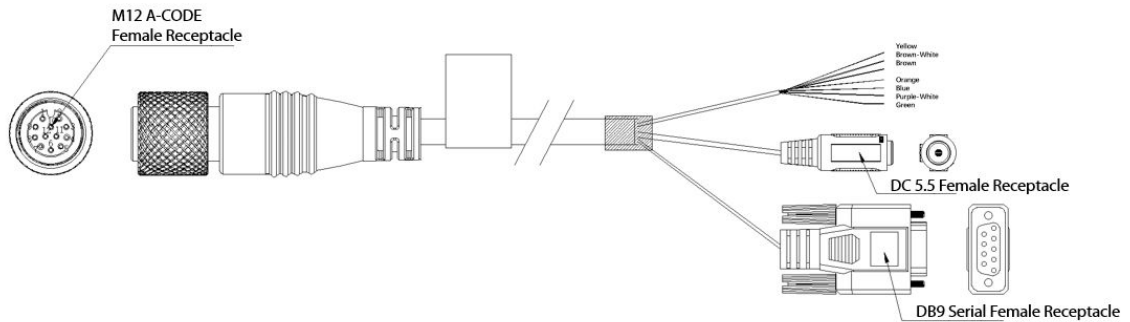


Figure 1-7 Serial Port Female Receptacle

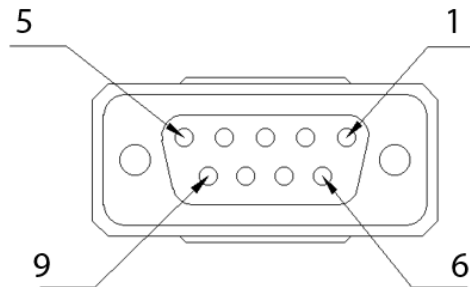


Table 1-3 Definitions Description

Pin	Signal	Description	Color
2	RS232_TXD	RS-232 serial port for sending	Gray
3	RS232_RXD	RS-232 serial port for receiving	Purple
5	SIGNAL_GND	RS-232 serial port GND	Black and white (casing)

- When using the device, it is recommended to use the cable as shown above.
- The ports of the cable for supplying power connecting to pin 7 and pin 8 have been made into DC5.5 female receptacles; therefore, no additional wiring is required.
- The pins of the cable corresponding to the RS-232, such as Pin 2, Pin 3, and Pin 4, have been made into a DB9 female receptacle; therefore, no additional wiring is required.
- Other pins of the cable can be wired according to the actual demands.

# 2 Electrical Specifications

## 2.1 Power Supply and Network Ports

Table 2-1 Specifications of Power and Network Ports

Item	Description
Power Supply	+9VDC ~+24VDC, <1% ripple, powered through 12-core M12 connector. 24AWG cable or thinner cable.
Data Output Ports	100M Ethernet
I/O Port	One RS-232 serial port (non-isolated) Two opto-isolated input ports (LINE0~LINE1) Three opto-isolated output ports (LINE0~LINE2)

## 2.2 I/O Ports

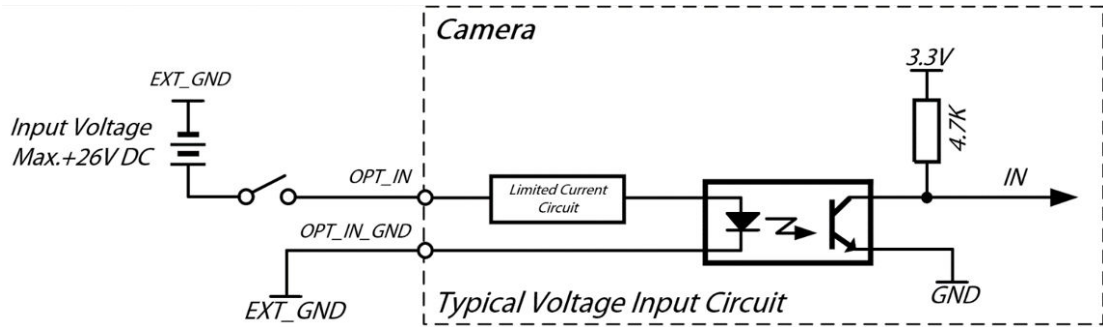
### 2.2.1 Opto-isolated Input

Table 2-2 Voltage Parameters

Input Voltage	Description
+26VDC	Extreme voltage. The input voltage cannot exceed the value. Otherwise, the device might be damaged.
+0VDC~+24VDC	Security working voltage range of I/O input.
+0VDC~+6VDC	Logic 0
+6VDC~+9VDC	The input status changes, and the logic status is unsteady within this voltage range.
>+9VDC	Logic 1

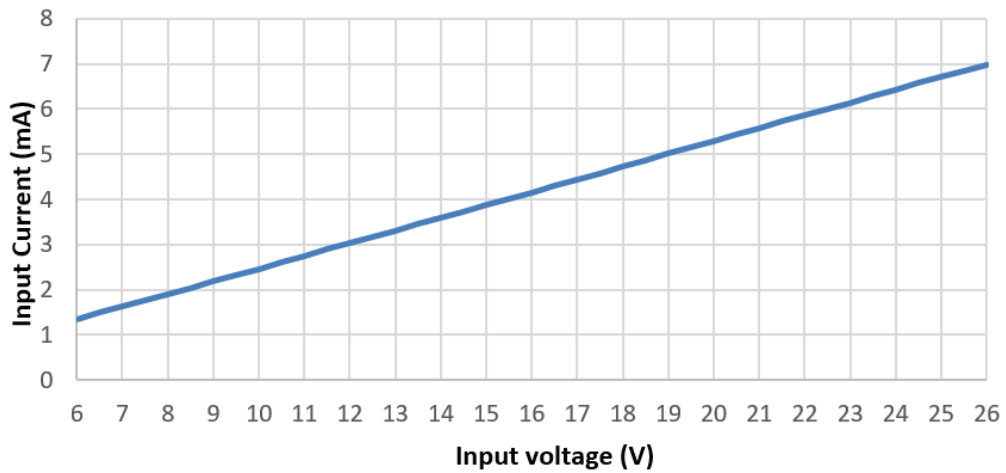
The typical circuit diagram of the opto-isolated input port is as follows.

Figure 2-1 Opto-isolated Output Typical Circuit



The relationship between the sink current and input voltage of the opto-isolated input port is as follows.

Figure 2-2 Opto-isolated Input Chart



- The maximum input current of the opto-isolated input can be up to 7mA.
- Values in the line chart are obtained at an environmental temperature of 25°C (77°F). Therefore, the actual values may vary among the different models of the sensor in the different environments.

The relationship between the input signal amplitude and trigger delay is as follows.

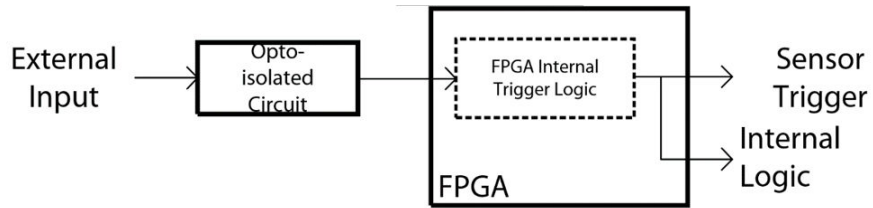
Table 2-3 Opto-isolated Input Signal Amplitude and Trigger Delay

Input Signal Amplitude (Vp-p)	Rising Edge Trigger Delay tDR (us)	Falling Edge Trigger Delay tDF (us)
9	18.8	23.70
12	7.20	31.30
20	3.00	38.40
24	2.40	40.10
26	2.20	41.40



The trigger input delay measures the time delay value from the external opto-isolated input port to the FPGA input pin, which means the internal logic delay of the FPGA is not included.

Figure 2-3 Delay Logic Diagram



Minimum input pulse width of the trigger input signal is described in the table below.

Table 2-4 Opto-isolated Input Signal and Minimum Pulse Width

Input Signal Amplitude (Vp-p)	Minimum Positive Pulse Width (us)	Minimum Negative Pulse Width (us)
9	36.00	90.00
12	10.10	90.00
20	3.10	90.00
24	2.40	90.00
26	2.10	90.00

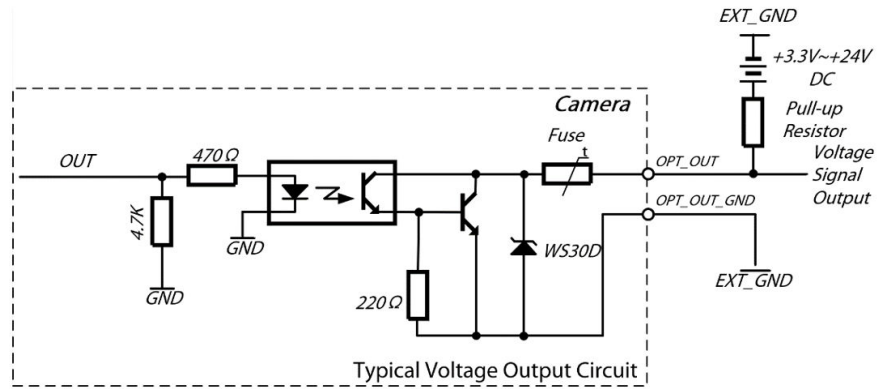
## 2.2.2 Opto-isolated Output

Table 2-5 Opto-isolated Output

Voltage	Description
+26VDC	Limiting voltage. Input voltage must not exceed this limit. Otherwise, it may cause damages to the devices.
<+3.3VDC	Possible error on I/O output.
+3.3VDC~+24VDC	Security working range of I/O output

The typical circuit diagram of opto-isolated output is as follows.

Figure 2-4 Opto-isolated Output Typical Circuit



The rising/falling time and rising/falling edge trigger delay time when using the 1 kΩ pull-up resistor are described in the table below, as shown in the following figure.

Figure 2-5 Internal Delay Diagram

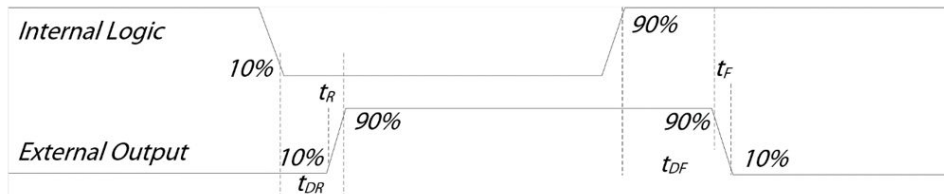


Table 2-6 Opto-isolated Output Signal Amplitude and Trigger Delay

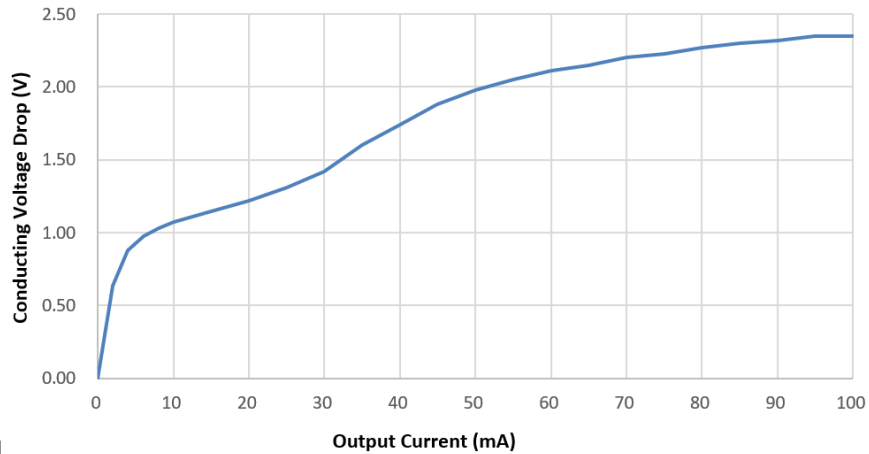
External Power Voltage (V)	Rising Time tR (us)	Falling Time tF (us)	Rising Edge Trigger Delay tDR (us)	Falling Edge Trigger Delay tDF (us)
5	19.70	3.20	39.9	8.06
12	24.06	5.22	44.8	11.8
24	30.11	8.10	44.8	53.2



- The output delay measures the delay time value from FPGA internal logic output to the external opto-isolated output pin, which means the FPGA internal logic delay is not included.
- Values in the line chart are obtained at an environmental temperature of 25°C (77°F). Therefore, the actual values may vary among the different models of sensor in the different environments.

The relationship between the output conducting voltage drop and output current is shown in the chart below.

Figure 2-6 Opto-isolated Output Chart



- The maximum conducting voltage drop at the opto-isolated output end is 2.35V. This result is obtained under the maximum output current 100mA.
- Values in the line chart are obtained at an environmental temperature of 25°C (77°F). Therefore, the actual values may vary among the different models of sensor in the different environments.

## 2.3 External I/O Wiring

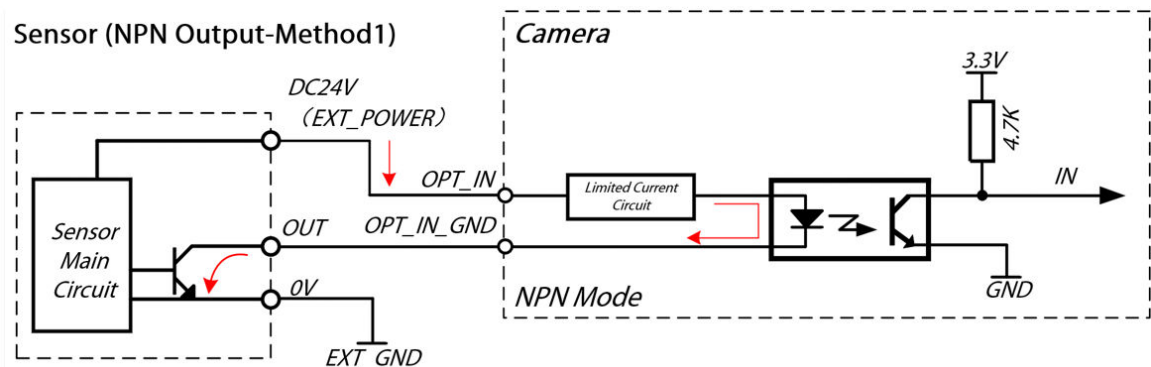
### 2.3.1 Opto-isolated Input

The opto-isolated input can be used with the sensors supporting the NPN, PNP, and push-pull output structures.

#### 2.3.1.1 NPN Output Structure

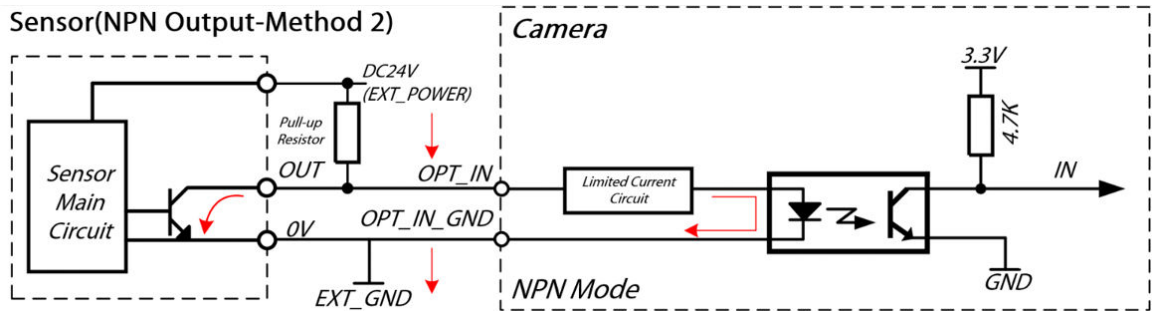
- Method 1: No Pull-up Resistor (Recommend)

Figure 2-7 Wiring Method of NPN Output Structure (1)



- Method 2: Add Pull-up Resistor

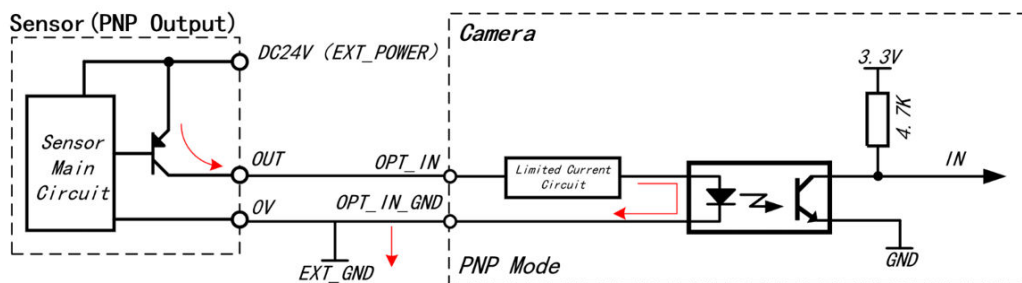
Figure 2-8 Wiring Method of NPN Output Structure (2)



- “EXT\_POWER” refers to the external positive port of power supply; “EXT\_GND” refers to the external power grounding port. The power supply can be the independent switch-type power supply, and also can be of the sensor.
- This wiring method is suitable for the sensors with NPN open-collector output structure.
- If the external pull-up resistance is adopted, the voltage and pull-up resistance shall be 1kΩ at 3.3V, 1kΩ at 5V, 2.4kΩ at 12V, 4.7kΩ at 24V. If user needs to improve the current capacity, the pull-up resistor shall be less than 1kΩ, and the rated power of shall be more than 1W.
- In some models, the “OPT\_IN\_GND” and “OPT\_OUT\_GND” are integrated as one common port, namely “OPT\_GND”.

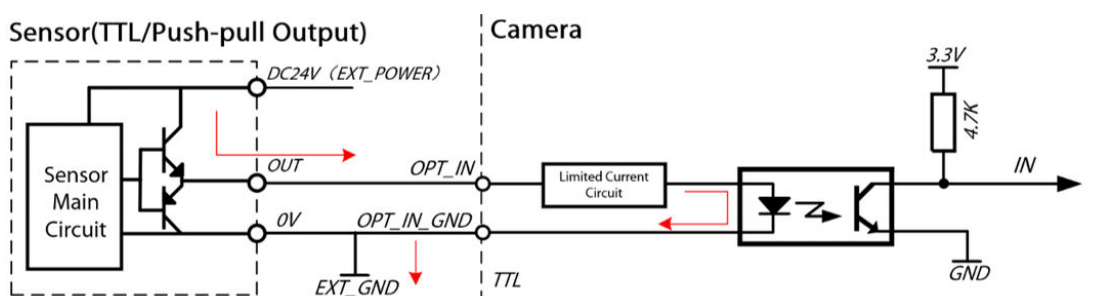
### 2.3.1.2 PNP Output Structure

Figure 2-9 Wiring Method of PNP Output Structure



### 2.3.1.3 TTL or Push-pull Output Structure

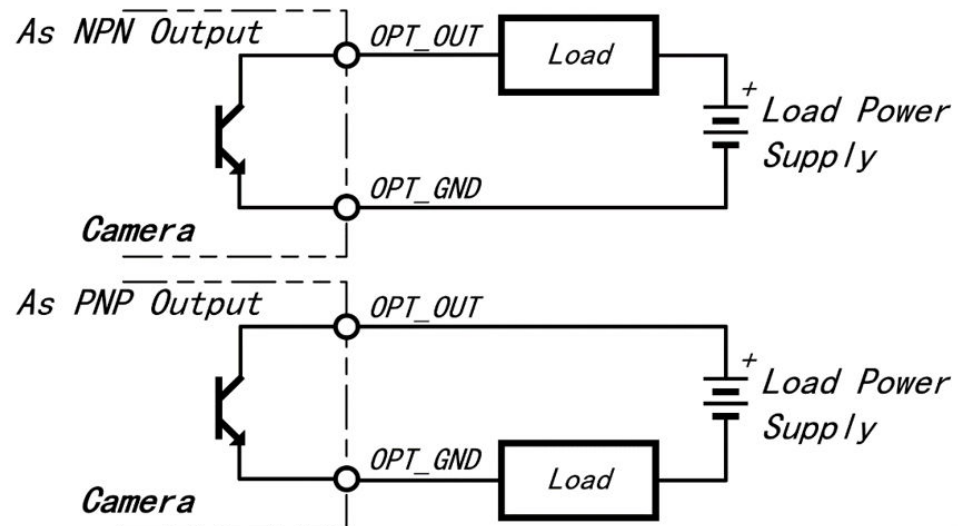
Figure 2-10 Wiring Method of TTL/ Push-pull Output Structure



## 2.3.2 Opto-isolator Output

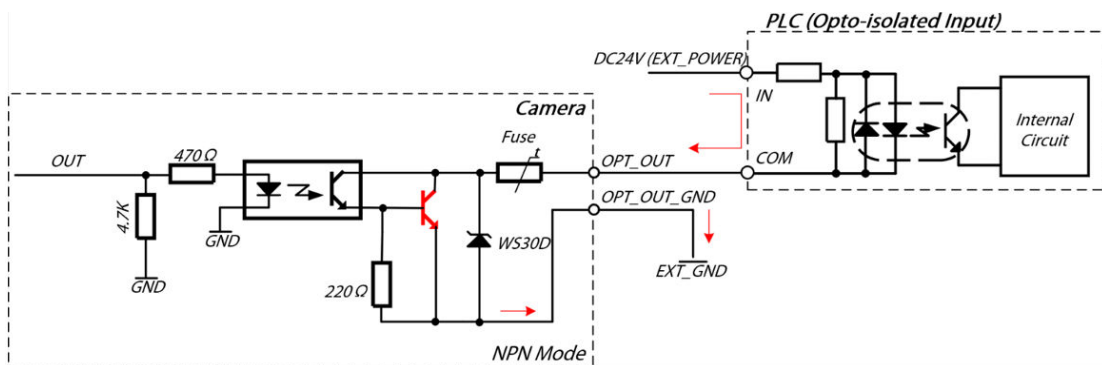
The transistor output port of sensor is separated from the internal loop by using an opto-isolator. Therefore, the transistor output port can be used as NPN output or PNP output.

Figure 2-11 Topology Diagram of Opto-isolated Output Structure



### 2.3.2.1 Vision Sensor as NPN Output

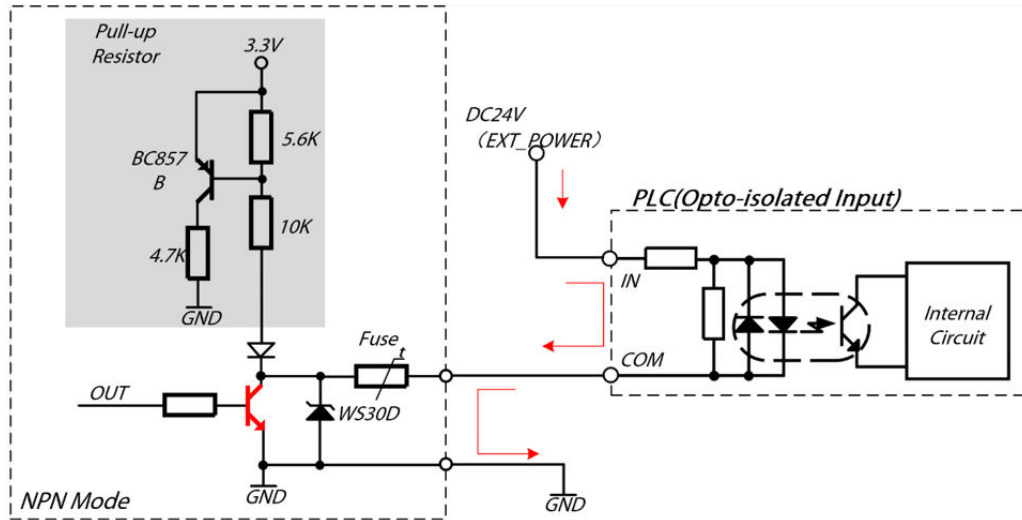
Figure 2-12 Wiring Method of NPN Output Structure (3)



### 2.3.2.2 GPIO as Output Port

When the GPIO is as the output port, it is similar to the opto-isolated output, and the difference between them is that the GPIO output should adopt the non-isolated wiring method, and the signal grounding port of GPIO and sensor should connect to the common grounding port.

Figure 2-13 Wiring Method of GPIO Output Structure



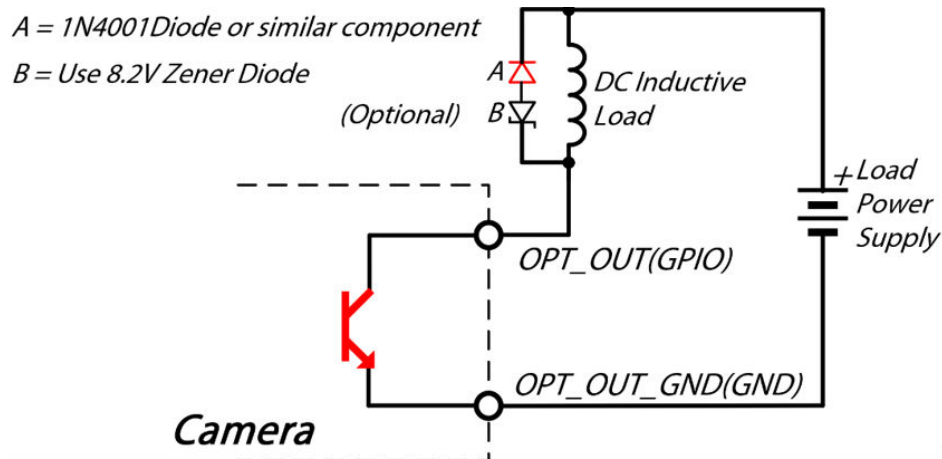
- Do not apply the voltage or connect load on the output terminals which exceeds the maximum value.
- Do not replace the fuse of the interface. If the fuse blows due to the overcurrent, such as short circuit, please contact our after-sales to provide the maintenance service.
- GPIO is the bidirectional port, and before connecting to the external power supply, please identify and set the correct the directions (output or input). Do not change the directions during the running of the sensor. The wrong settings of directions will cause damages to the circuit of the GPIO interface.
- Please do not use the GPIO output solution in the situation with serious electrical interference, because the GPIO is the non-isolated design which means its anti-inference performance is not good enough. We recommend you use the opto-isolated input port or output port.
- If the external pull-up resistance is adopted, the voltage and pull-up resistance shall be 1k $\Omega$  at 3.3V, 1k $\Omega$  at 5V, 2.4k $\Omega$  at 12V, 4.7k $\Omega$  at 24V. If user needs to improve the current output capacity, the resistance should be less than 1k $\Omega$ , and the rated power of it should be more than 1W.

### 2.3.2.3 Wiring Method of Relay or Other Inductive Loads

To drive the inductive load, such as relay, using sensor output signals, please use relay with built-in flyback diodes, or use the external flyback diodes. Otherwise, the overvoltage will cause damages on the output interface.

The diagram below is an example of the suppression circuit of DC inductive load. In most solutions, one additional diode A is required. If you need the faster shutdown speed, we recommend you use the Zener diode B. Please ensure that the Zener diode can meet the current requirements of the circuit.

Figure 2-14 Wiring Method of Inductive Load



## 2.4 How to Avoid EMI and ESD

In the industrial environment, there are some equipment generating EMI, and the vision sensor is apt to be influenced by ESD. Serious EMI and ESD can lead to false triggering or sudden stop of streaming. EMI and ESD will also bring instability to the image quality, and interfere the reliability of image transmission between sensor and PC.

In order to avoid the problems mentioned above caused by EMI and ESD, we recommend you take the following measurements:

- Use high quality shielded cables, which can play a good effect on shielding EMI and ESD.
- Appropriate cable length is important. If the cable length is longer than expected, please fold the redundant part instead of looping it.
- Data transmission cable is suggested to be paralleled with the power cable.
- Camera cable should not be closely paralleled with other cables which has heavy current or has situations of voltage switching, such as stepper motor drive, solenoid valve.
- We recommend you connect all the grounding (GND) wires to a single point, i.e., single point grounding. For example, a distribution board should be used to connect the grounding wires of the whole system to a single point, which can avoid the ground loop, which is the major cause of EMI problems.
- Use a line filter for the main power supply of the sensor, or a separate power supply for sensor is recommended.
- Please keep sensor and its cables away from the device generating sparks, such as brushed motors, relays, etc. A metal shielding shell is recommended if it is necessary.
- The following measurements can be taken to reduce the risk of ESD:
  - ◇ The mounting surface shall be adopted with conductive material.
  - ◇ The humidity in the installation environment shall be properly controlled. Dry air is easy to produce ESD.

# 3 Installation

## 3.1 Precautions

When installing the devices, please avoid the situations which can generate the static electricity, electromagnetic interference, lightning strike or surge as well as the heat dissipation of the devices.

### 3.1.1 Safety Requirements

Although the interior of the device is designed to protect against lightning, surge, EMI and ESD, from the perspective of safety, it is necessary to take measures to avoid or reduce these effects.

The followings are the basic protection methods:

- Adopt shielded network cables in SFTP structure. When meeting the usage requirements, please do not overly coil the network cable.
- The network cable should not be too long. If the network cable is too long, do not coil the redundant portion in an O-shape; it should be arranged in an S-shape to minimize the effect of electromagnetic interference.
- Adopt power control cables with interference shielding function. Do not coil the cable in O-shaped, it can be wired in parallel with the network cable, but should avoid winding each other.
- The power cable and network cable shall be far away from the equipment with large current, high voltage, frequent power on and off, start and stop, such as stepper motor. In particular, it shall not be wired in parallel with the cable of such equipment. This kind of device has strong electromagnetic radiation, which can be easily coupled to the transmission line of the equipment.
- The protective GND of all devices shall be connected together, and then connected to the protective GND at a single point to avoid multi-point grounding. Multi-point grounding is easy to cause the voltage difference between each device, forming a loop, which is easy to couple electromagnetic interference.
- The AC power supply end of the switching power supply for the equipment and PC should come from the same AC socket, so that their protection GND can be connected together to avoid multi-point grounding. The high-power electromechanical device should not connect to the same AC power.
- The magnetic ring can be adopted to the power control line of the device to absorb the electromagnetic interference signals.
- To reduce the ESD, the ESD wrist strap, anti-static clothing and shoes are recommended to wear, and the environment humidity shall be maintained in a proper range.

### 3.1.2 Heat Dissipation Requirements

The environmental requirements of vision sensor are as follows:

- Temperature and humidity
  - ◇ The ambient temperature cannot exceed 50°C (122°F), and it is best for the device to work in an air-conditioned environment.
  - ◇ Ambient Humidity: 20%~80%, non-condensing.
  - ◇ Storage Temperature: -30°C ~ +80°C (-22 °F~+176 °F).
  - ◇ Storage Humidity: 20%~80%, non-condensing.

- Do not coil the excessive cable into a loop, please bend it back and forth instead of coiling into a loop to ensure the performance of EMI.
- Do not bump the button during the transportation and assembly to prevent damage to the metal dome array.

## 3.2 Hardware Installation

### 3.2.1 Packing List

After unpacking the box, check if there are obvious damages to the appearance of the device, and make sure the components are complete against the packing list, see the table below for more details.

Table 3-1 Parts List

No.	Item	Quantity
1	Vision Sensor	1
2	M3×6 Phillips-head Screw	4

### 3.2.2 Accessories and Installation

For the hardware installation, please prepare the items described in the list below.

Table 3-2 Accessory List

No.	Item	Quantity	Description
1	Vision Sensor	1	Device mentioned in this manual
2	Power Supply Cable and I/O Cable	1	Need to buy independently
3	Ethernet Cable	1	This accessory should be purchased independently.
4	Switch-type Power or Power Adapter	1	Select the appropriate power adapter or switching power supply according to specifications of power supply and power consumption of the device. Please refer to the corresponding technical specification manual for more details. The power adapter and switching power supply are needed to be purchased separately.
5	Fixing Bracket	1	For fixing the device. This accessory should be purchased independently. For more details of device installation, please refer to the diagrams of 3-1 and 3-2.

No.	Item	Quantity	Description
6	Adapter Bracket	1	For fixing the device. Combing with the fixing bracket will provide the multi-angle adjustment of the fixing mode of the vision sensor.

Figure 3-1 Installation Method (1)

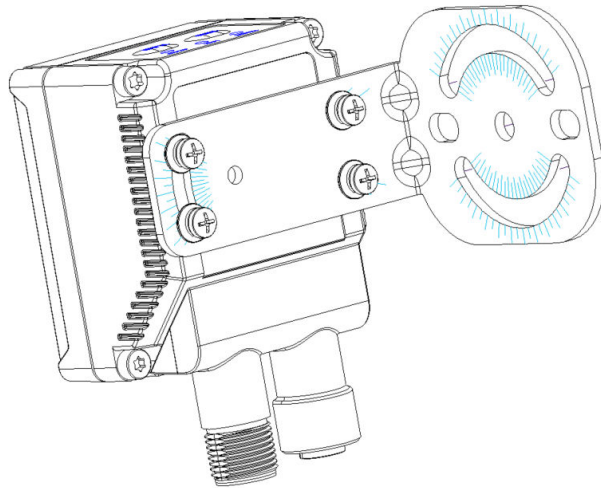
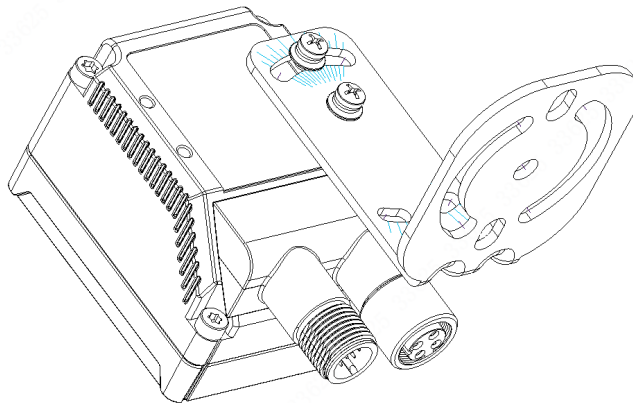


Figure 3-2 Installation Method (2)

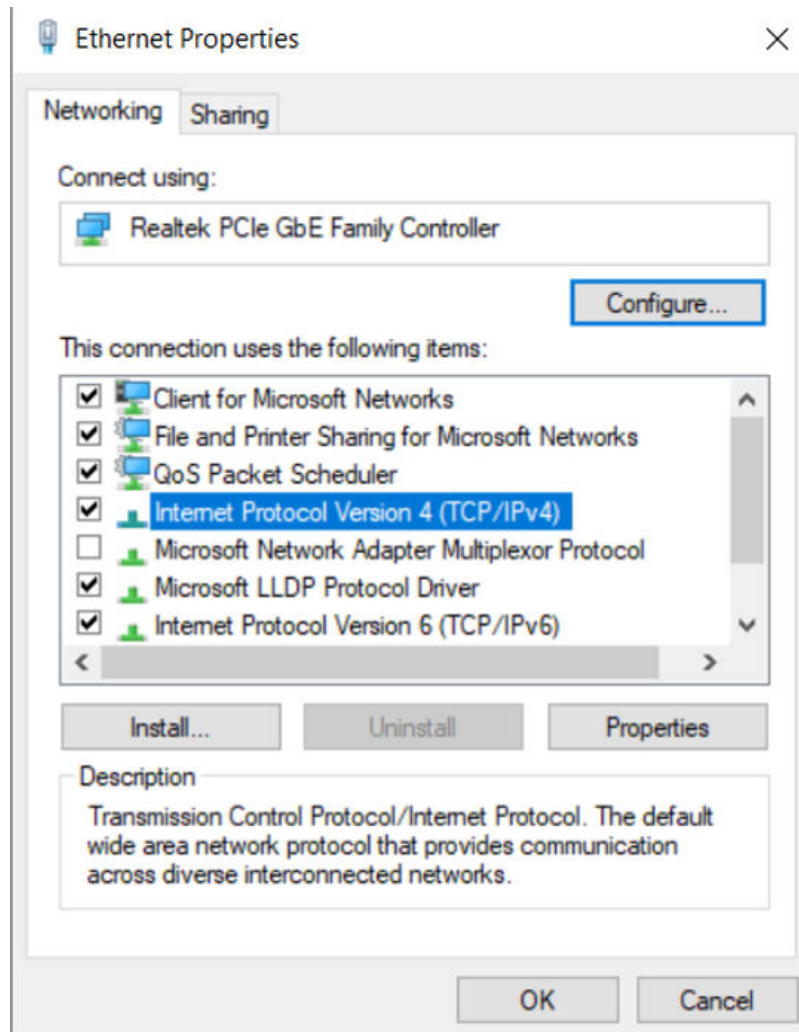


### 3.3 Network Settings

#### Procedure

- Step 1 Select **Control Panel > Network and Internet > Network and Sharing Center > Change Adapter Configuration**. Select the corresponding network port and right-click **Properties** from the shortcut menu. A dialog box is displayed.

Figure 3-3 Attribute Settings of NIC

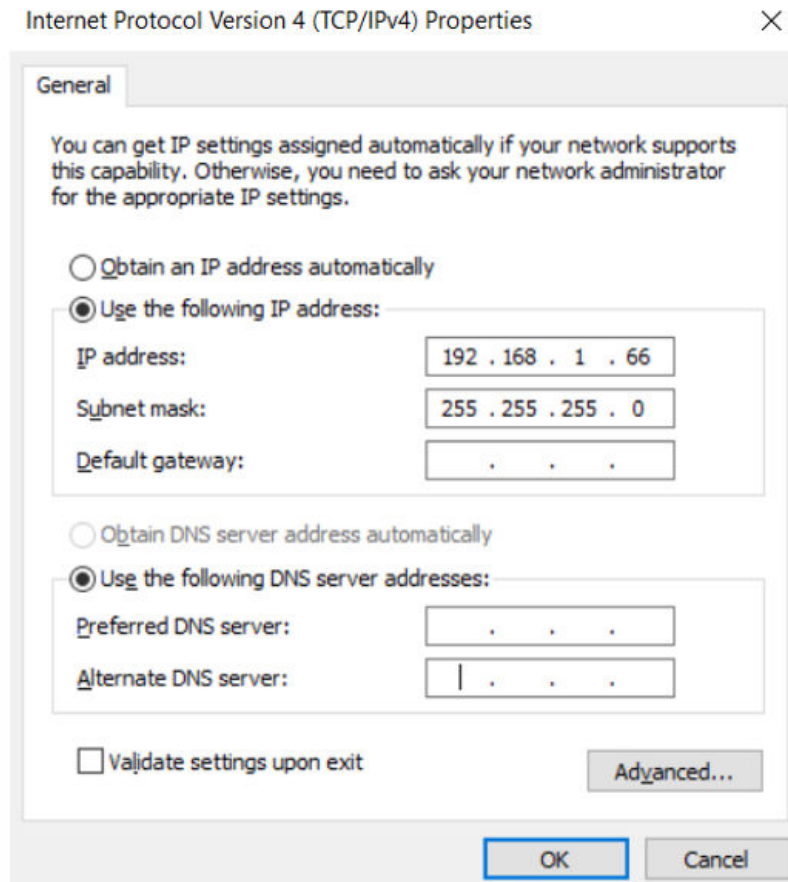


Step 2 Double-click **Internet Protocol Version 4 (TCP/IPv4)**. The IP address setting interface will be popped up. Configure the network port to the static IP address. Ensure that the PC and the device are on the same LAN.



Default IP Address: 192.168.1.108

Figure 3-4 Windows NIC Configuration



# 4 Client Software

The client software EasyVS now supports the access mode of Web to configure the device. After connecting the device, user can manage the projects, such as creating, edition, initialization or copying, project switching, etc. The wizard-type guideline helps user to configure the project. The main steps include Shooting Setup, Master Registration, Algorithm Setup, Communication Setup. The EasyVS supports the functions of device management and monitoring, the web-access mode is integrated in the client software; therefore, user does not need to install the additional software.

## 4.1 Desktop Client

### 4.1.1 Configuration Requirement

To ensure that the normal operation of the client, the requirements to the PC are as follows.

Table 4-1 Configuration Description

Item	Standard Configuration	Recommend Configuration
Operating System	64-bit Windows 10 or above	64-bit Windows 10
CPU	Intel E3940	Intel i5-10500
Memory	4GB	8GB or above
Graphics Card	1440*900 or above	1440*900 or above
NIC	100M	GigE

### 4.1.2 Install Client

User can perform the image procession and parameter setting on the EasyVS.

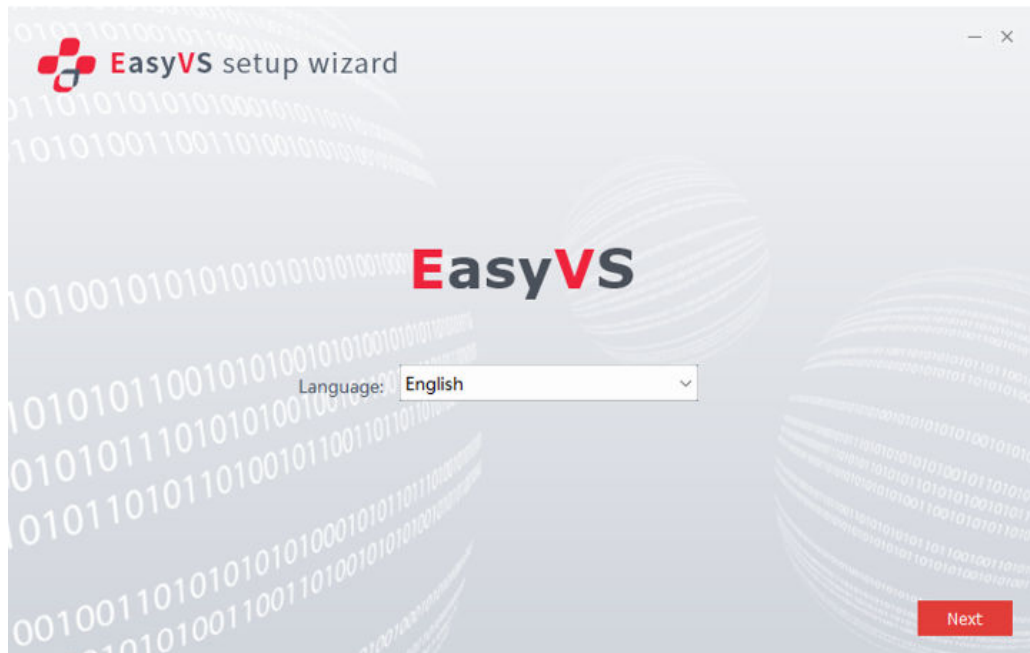


User can obtain the latest client software on our official website.

#### Procedure

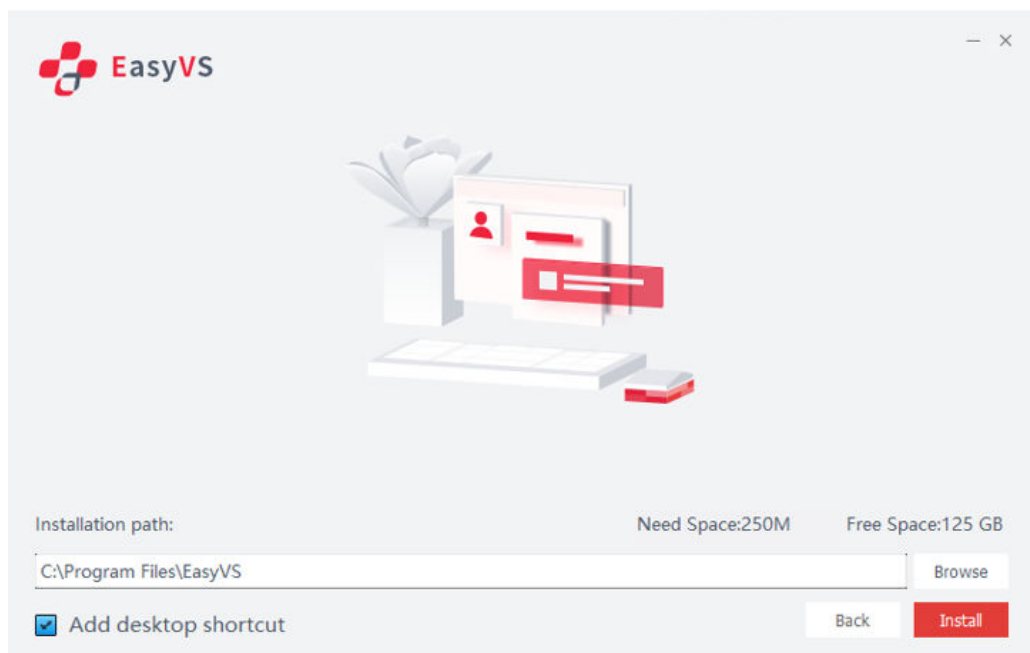
- Step 1** Double-click EasyID\_Vx.x.xx\_xxxxxxx.exe to run the program, or right-click it and click **Open**, the installation procedure will begin.

Figure 4-1 EasyVS Installation Interface



Step 2 Click **Next**, and then select the installation path.

Figure 4-2 Installation Path Selection



Step 3 Click **Install** to proceed automatic installation procedure, the automatic installation will take about one minute.

Figure 4-3 Installation Progress

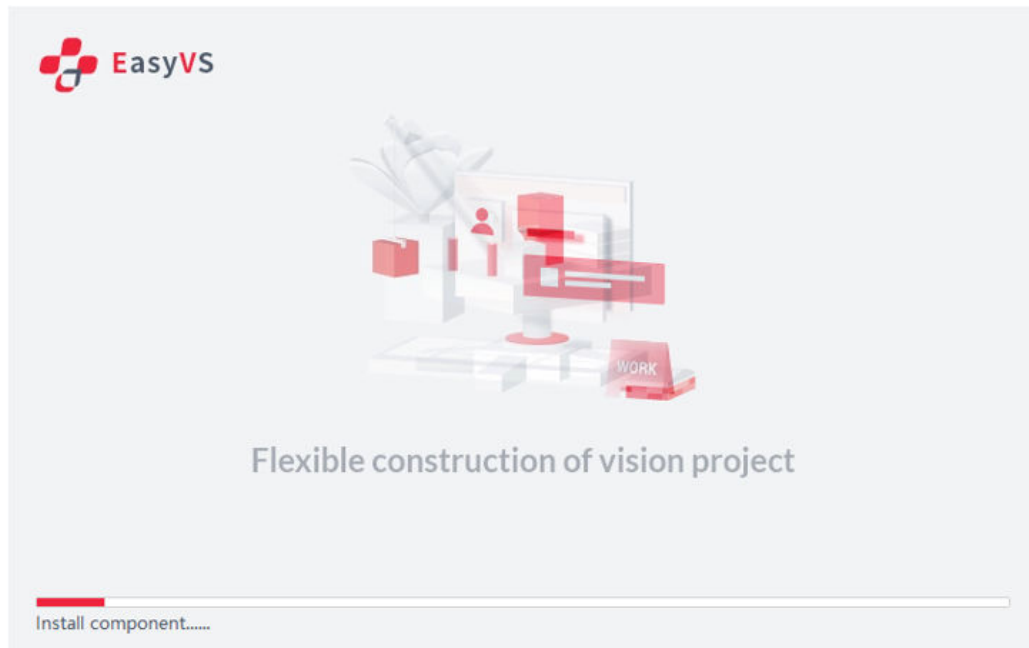
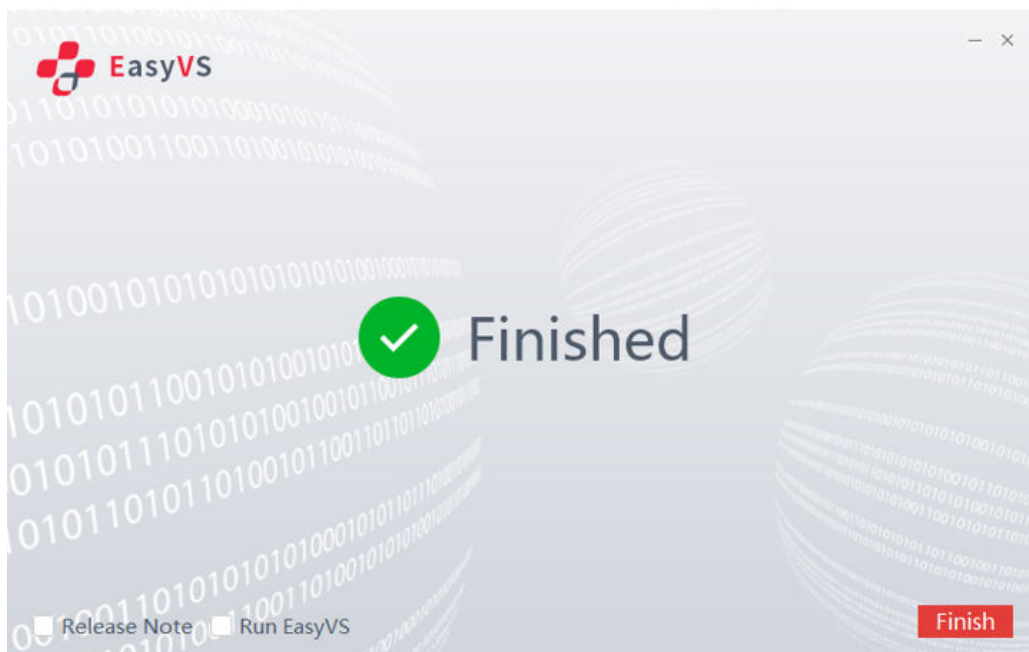


Figure 4-4 Installation Complete



**Step 4** After selecting **Run EasyVS**, click **Finish**. After the installation is finished, the software runs automatically.

Figure 4-5 Homepage

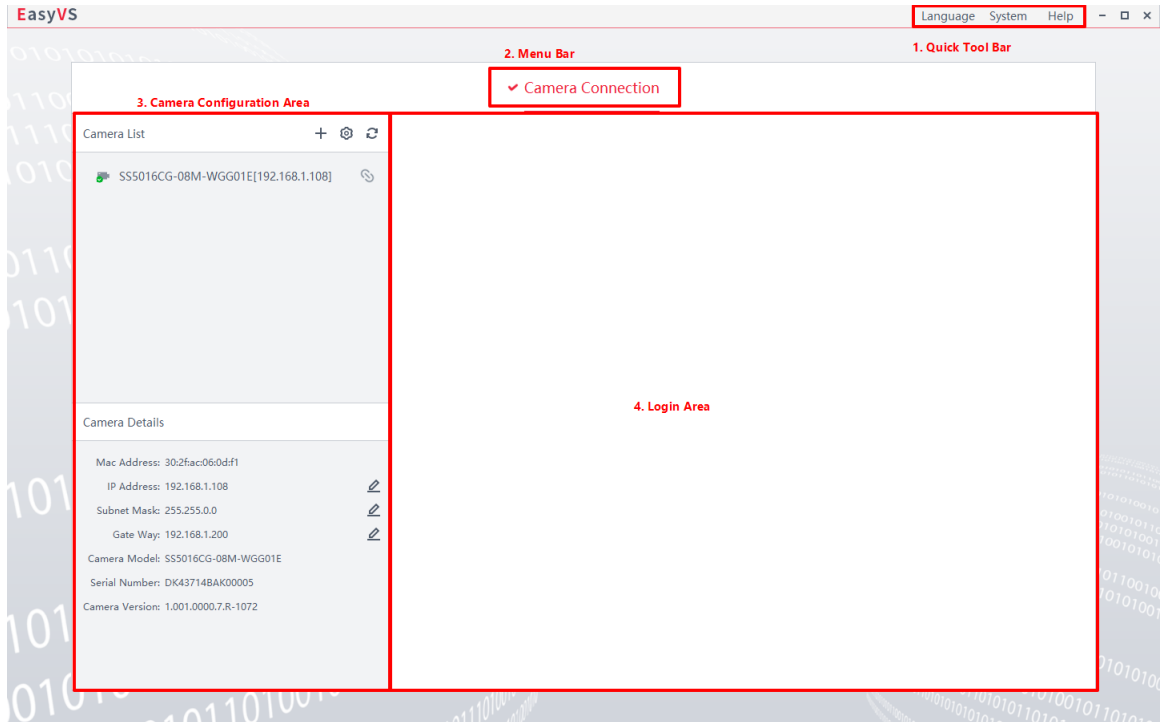


Table 4-2 Homepage Description

No.	Function	Description
1	Quick Tool Bar	It includes the settings of language, help document, version information, firmware upgrade tool, and image saving parameter configuration
2	Menu Bar	User can connect the device in the device list.
3	Camera Configuration Area	User can perform Add IP, IP Config, Refresh, etc., and user can check the information of the device under the device list.
4	Login Area	After completing the connection between the device and client, user can login to enter the control console, and perform algorithm settings, project management, and device configuration.

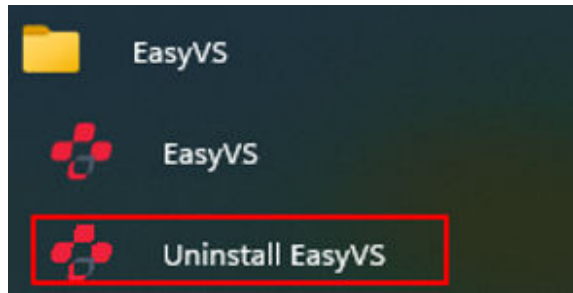
### 4.1.3 Uninstall Client

The procedures of the client uninstallation below are performed on the Windows 10. The specific procedures may vary depending on which version of operating system you use.

#### Procedure

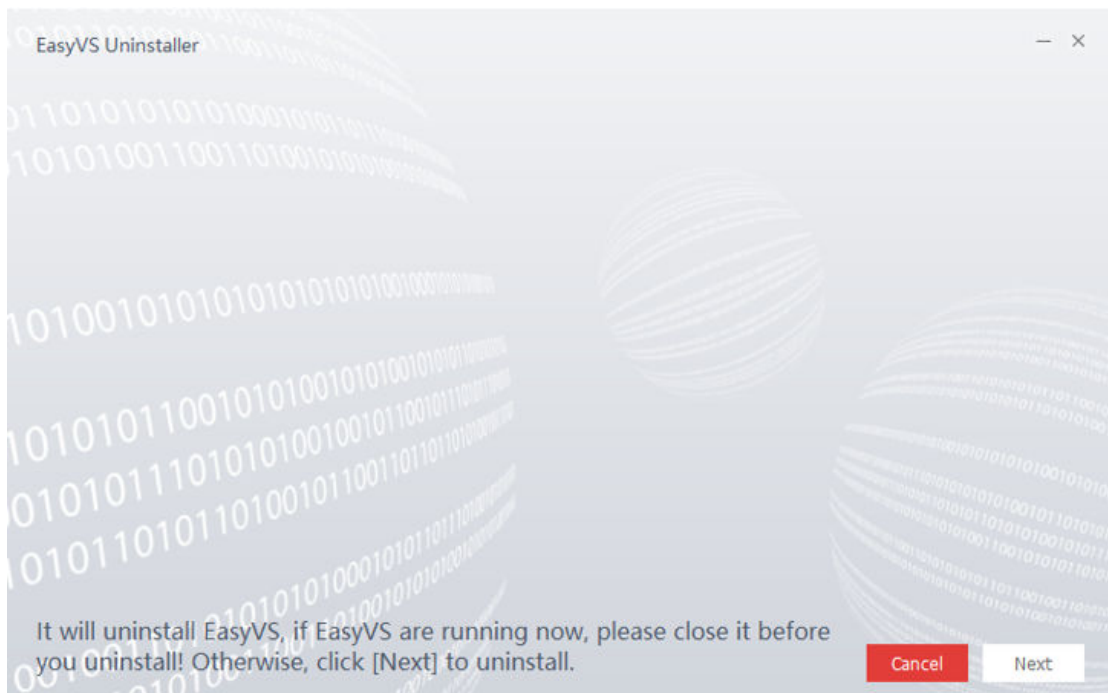
- Step 1** Click **Start** on the **Task Bar**, find and click the folder of the EasyVS, and click the **Uninstall EasyVS**.

Figure 4-6 Uninstallation



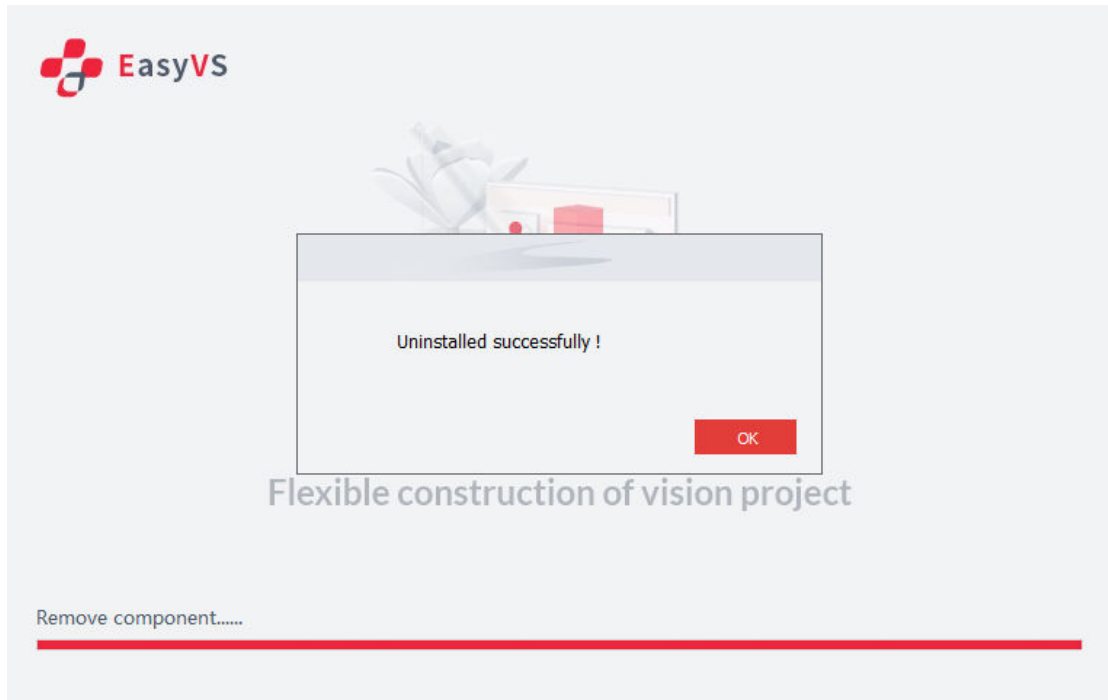
Step 2 After starting the uninstallation program, click **Next**.

Figure 4-7 Start Uninstallation



Step 3 After the progress bar is completed, click **OK** to complete the uninstallation.

Figure 4-8 Uninstallation Completed



## 4.1.4 Client Operations

### 4.1.4.1 Connect Device

#### Procedure


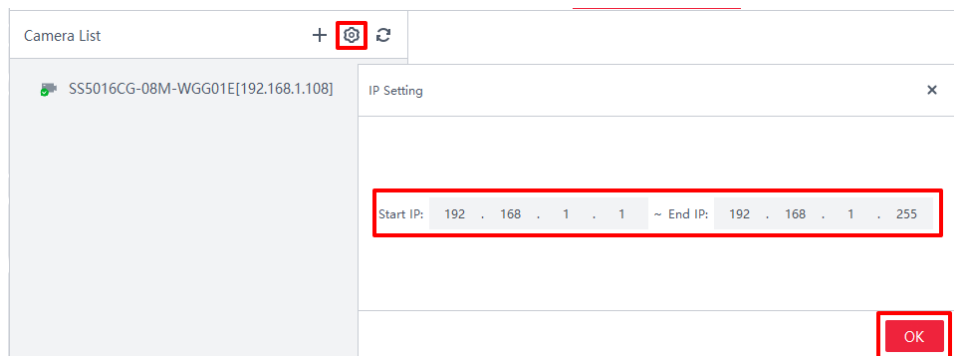

- Step 1** Connect the sensor normally, and ensure that the power supply and network of the sensor are both normal by checking the indicators on the vision sensor. After that, open the EasyVS. If the sensor is connected to the NIC or ordinary switch, the sensor will be displayed in the device list of EasyVS without IP configurations; if the sensor is connected to the three-layer switch, click  to enter the IP network segment configuration interface, and modify the IP network segment of the sensor.

Figure 4-9 Set IP Network Segment



- When the sensor is connected to the three-layer switch, user shall ensure that the sensor can connect to the client using the ICMP.

- If user wants to keep the firewall enabled, the EasyVS needs to be added in the allow-list; otherwise, the client cannot find the sensor.
- After configuring the IP network segment, the device list will display the sensor in the same network segment with the PC. When new devices come online, click  to refresh the list. The IP address of sensor is 192.168.1.108 by default.
- Under the same LAN, check the IP address of the sensor before using to avoid IP address conflict among sensors.


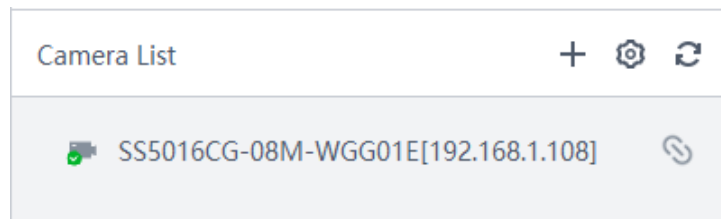
Step 2 Click  to add the IP address of the sensor. This is suitable for the sensor connected through the three-layer switch which is not in the same network segment with the PC. After adding the IP address of sensor, click **OK**, and the device list will display the device.

Figure 4-10 Add IP Address



Figure 4-11 Camera List




Step 3 Click  to enter the configuration interface of IP address, enter the IP address, and click **OK**, as shown in the figure below.

Figure 4-12 IP Address Configuration

Modify IP [X]

Static IP       DHCP

IP Address: 192 . 168 . 1 . 108

Subnet Mask: 255 . 255 . 0 . 0


Gateway: 192 . 168 . 1 . 200

User Name: admin

Password: [Masked]

Cancel    OK

Step 4 Click the sensor in the device list, the login area will show the login box. User needs to enter the username and password, and click **Login** to enter the configuration interface.

- If the icon in the left side of the sensor name in the device list turns into the , it means that the sensor connection is successful.



- Default Username: admin
- Default Password: admin123

Step 5 The right area will display the login window. Click **Login** to enter the homepage of the sensor configuration. See the following figure.

Figure 4-13 Login

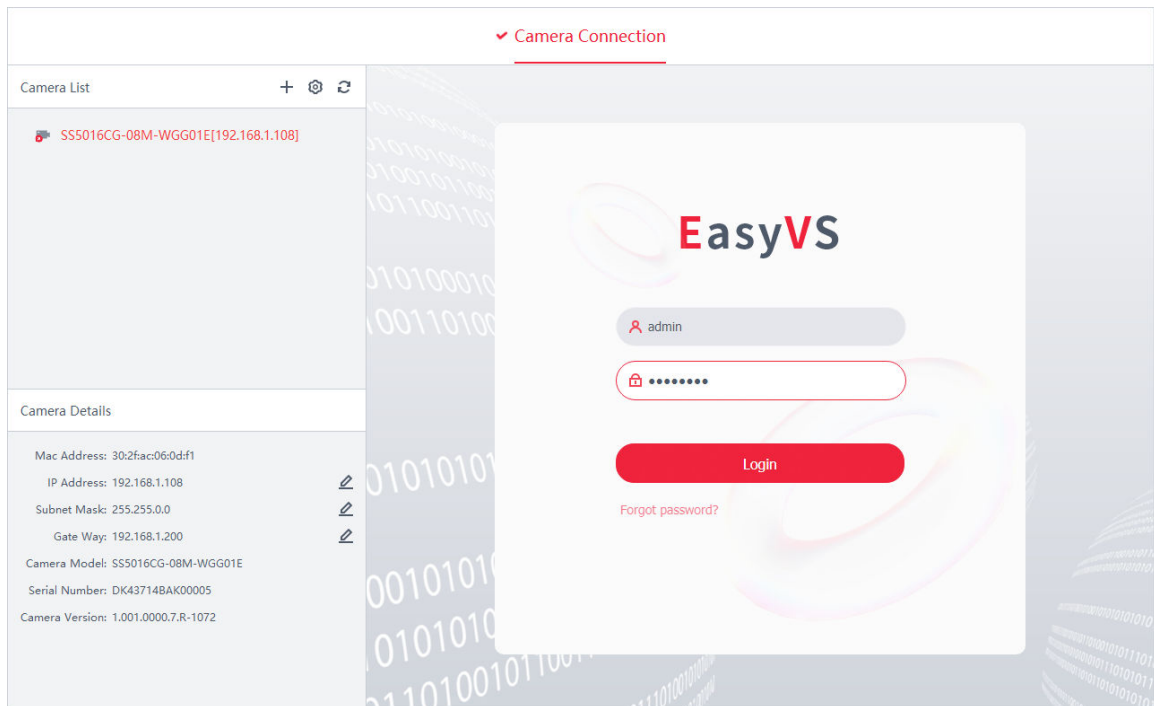
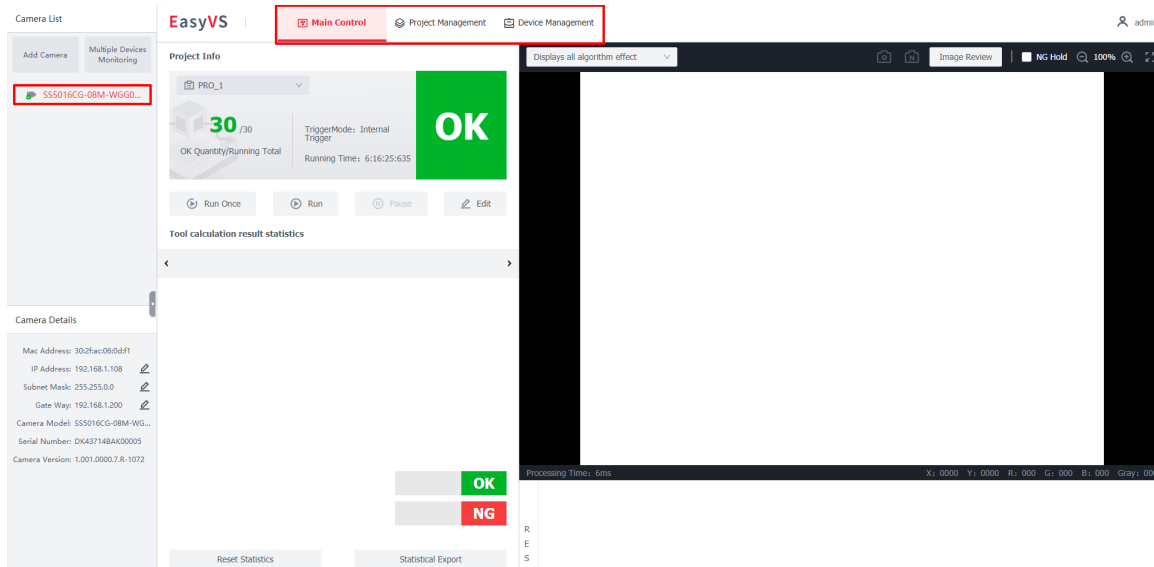


Figure 4-14 Enter the Homepage



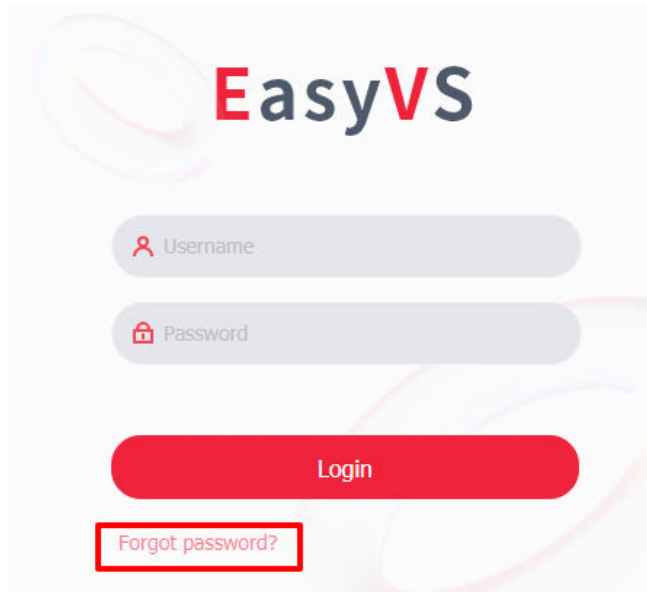
#### 4.1.4.2 Password Reset

If user forgets the password, user can perform the password resetting by clicking the Forget Password.

#### Procedure

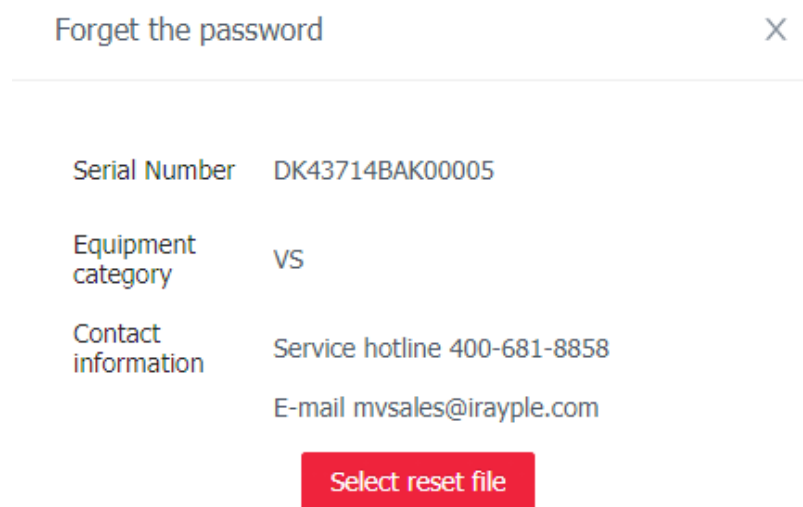
**Step 1** Click **Forgot Password**.

Figure 4-15 Forget Password



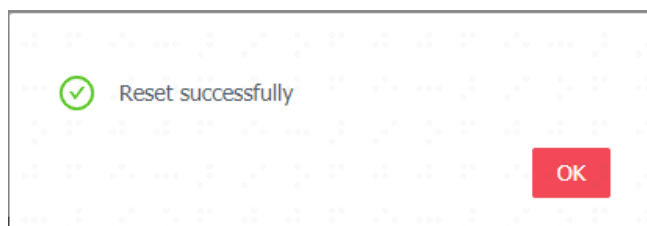
Step 2 Contact after-sales or send us emails, and provide the serial number of the sensor and user's requirement of password resetting to obtain the password reset file.

Figure 4-16 Contact Information



Step 3 Click **Select Reset File**, select the password reset file which our technical specialist provided, and import the file into the sensor. A prompt box saying Reset Successfully will pop up.

Figure 4-17 Reset Successfully



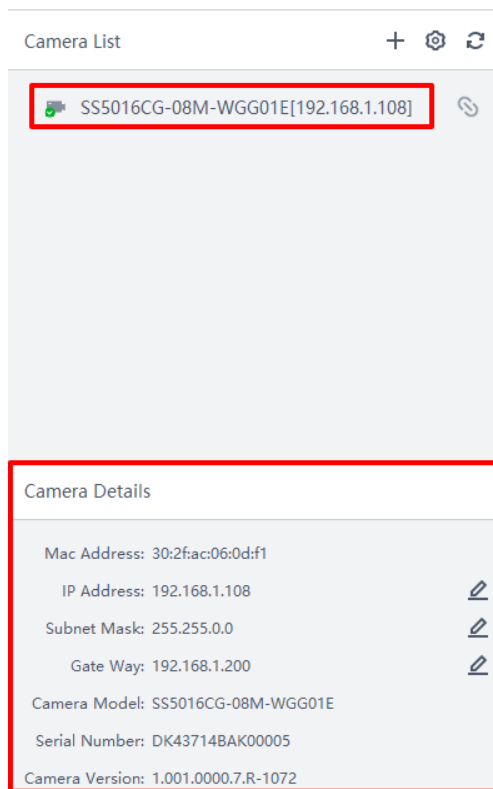


The default username and password are **admin** and **admin123** respectively. Considering the security of the device, we highly suggest you modify the password after resetting it.

### 4.1.4.3 Camera Details

Select the device in the device list, the relevant information of device will be displayed in the Camera Details area, which includes IP address, Mac address, sensor model, sensor version (firmware version), serial number, as shown in the figure below.

Figure 4-18 Camera Details



If an abnormal device needs to be checked by the vendor, please provide the device information, such as model, firmware version, and serial number to the sales or technical specialist.

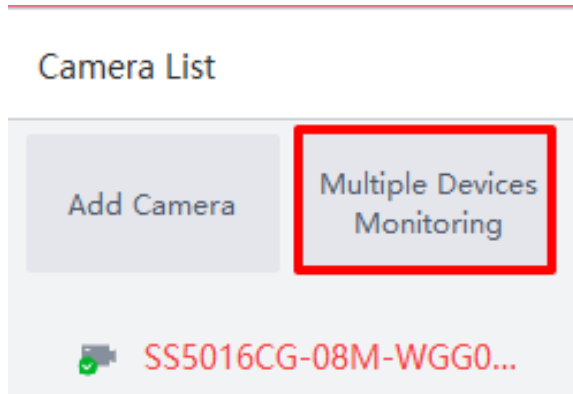
### 4.1.4.4 Multiple Channels

If there are multiple sensors connecting to the EasyVS, user can use the multiple-channel function to monitor multiple sensors.

#### Procedure

- Step 1** Click the sensor name in the device list and log in, and click **Multiple Devices Monitoring**.

Figure 4-19 Multiple Devices Monitoring



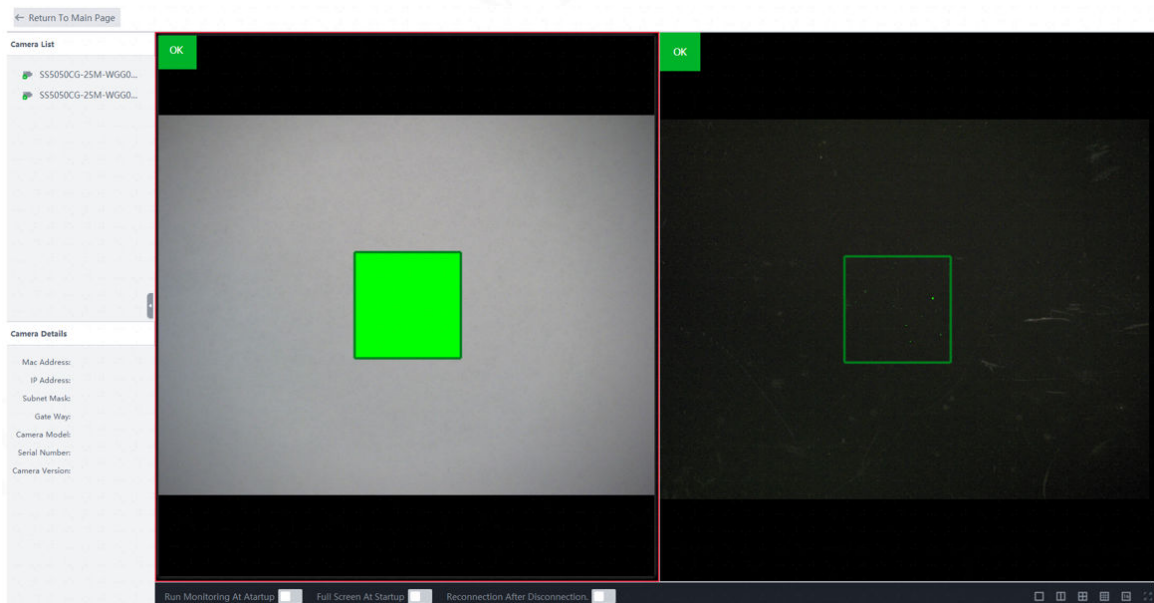
**Step 2** Click **Multiple Devices Monitoring** to enter the monitoring interface. After adjusting the ratio, click the sensors in the device list to perform multiple-channel monitoring function. Click the **Return to Main Page** in the top left of the interface to return to the main control interface. User can also adjust the ratio of the multiple-channel interface in the bottom right of the monitoring window. The options include 1\*1, 2\*1, 2\*2, 3\*3, and 4\*4.

Figure 4-20 Split Settings



- After enabling the **Run Monitoring at Startup**, user can directly enter monitoring interface when start the EasyVS.
- After enabling the **Full Screen at Startup**, the monitoring interface is in the full screen mode by default.
- After enabling the **Reconnection after Disconnection**, the client will automatically connect the sensor when it is disconnection.

Figure 4-21 Multiple-channel Monitoring Interface

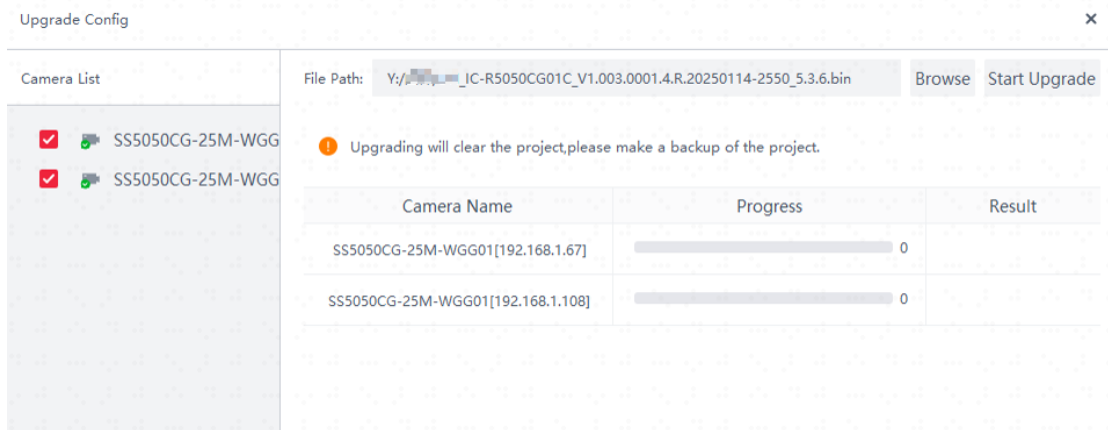


## 4.1.4.5 Firmware Upgrade

### Procedure

- Step 1** Click **System** > **Upgrade** in the **Quick Access Bar**, the **Firmware Config** tool will pop up. User can perform the firmware upgrading to the multiple sensors.

Figure 4-22 Batch Upgrading

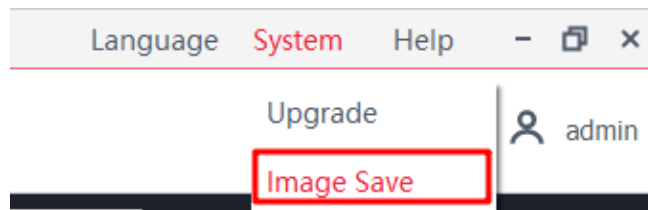


## 4.1.5 Image Save

### 4.1.5.1 Save Picture Config

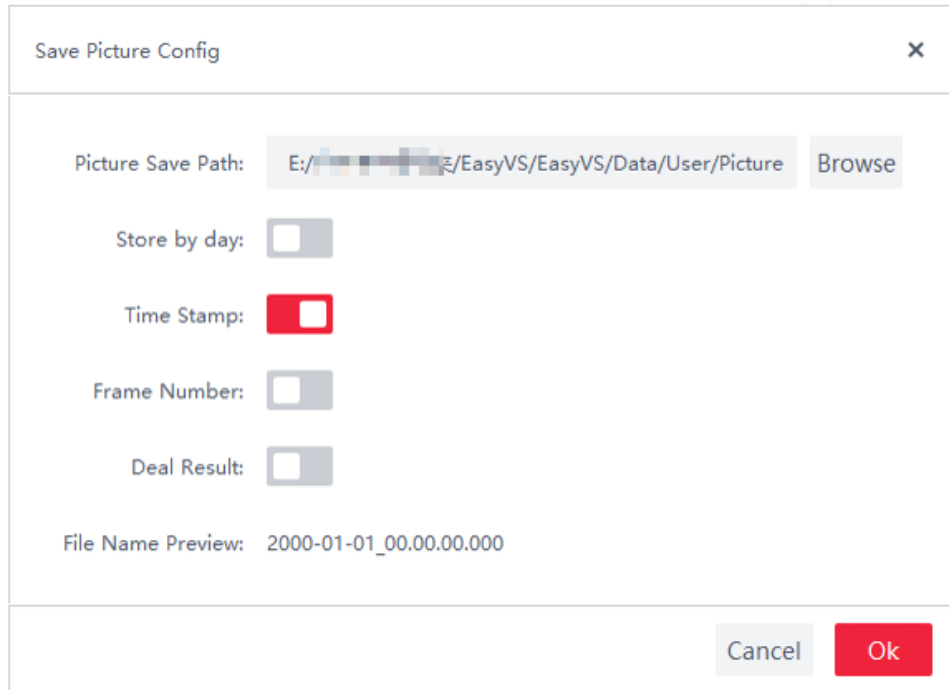
Click **System** > **Image Save**, the **Save Picture Config** interface will pop up.

Figure 4-23 Image Save



User can set the relevant configurations in the Save Picture Config, such as picture save path, frame number, deal result, and store by day. The time stamp is a fixed option, which cannot be configured.

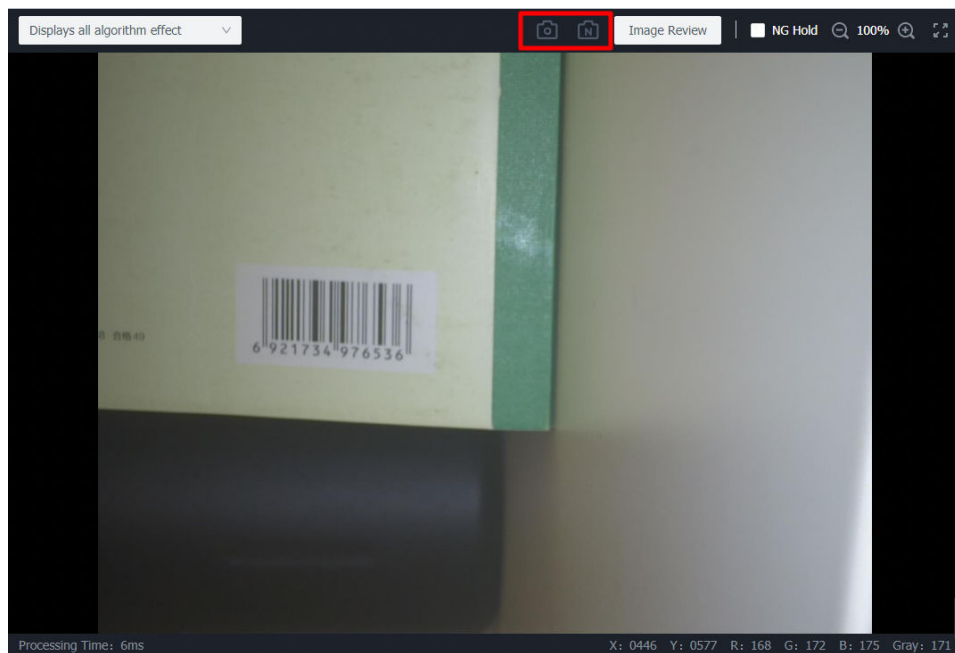
Figure 4-24 Save Picture Config



#### 4.1.5.2 Image Saving Operation

There are two image saving methods in the image display area, including snapshot and continuous saving. The snapshot is performed once by one click, which only saves one image; the continuous saving is enabled by one click, it will save images continuously until user clicks the button one more time.

Figure 4-25 Image Saving



## 4.2 Web Client

### 4.2.1 Compatibility Requirement

The following browsers are highly recommended.

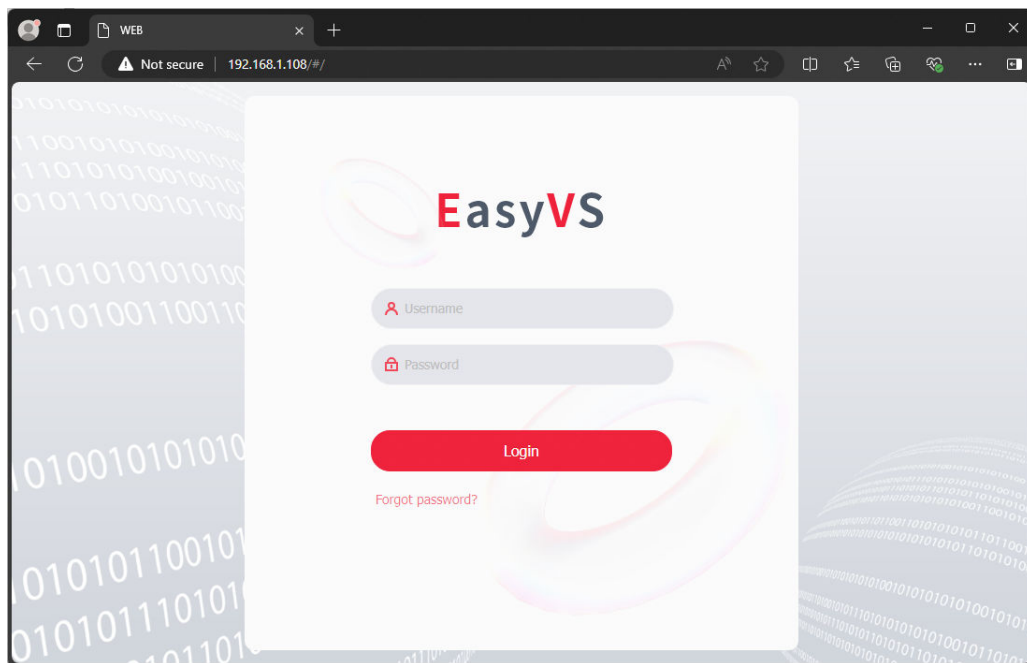
- Google Chrome: Version 127.0 or later.
- FireFox: Version 116.0 or later
- Edge: Version 95.0 or later.

### 4.2.2 Web Client Operation

#### Procedure

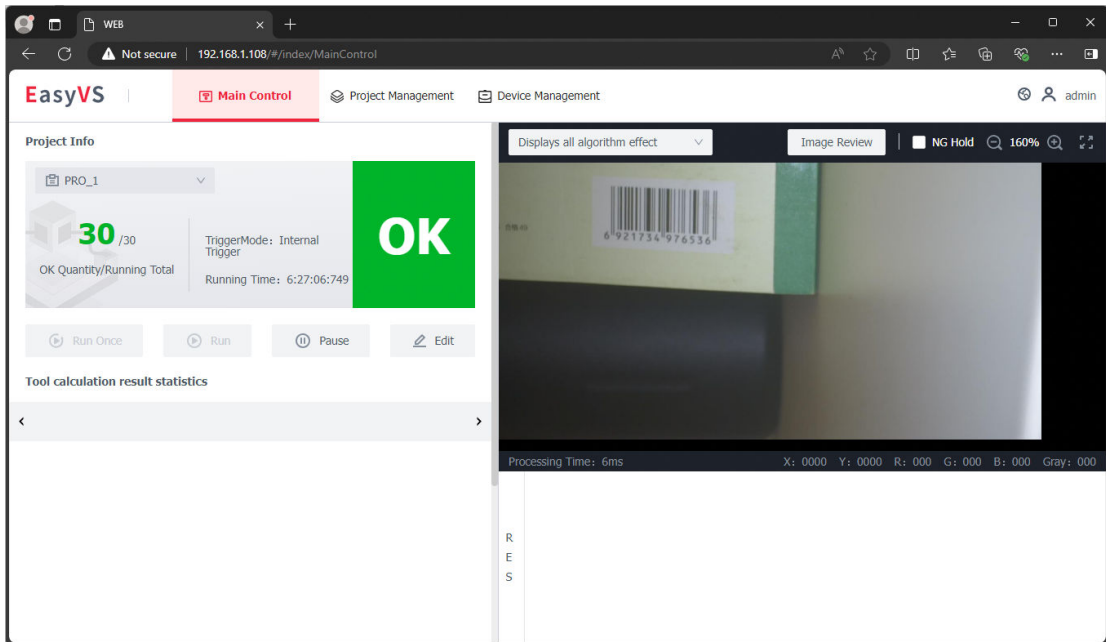
- Step 1 Enter the IP address of the sensor in the browser, and press **【Enter】** to enter the web client of EasyVS. After entering the web client, enter the username and password to login the configuration interface. If user forgets the password of the sensor, please refer to the **4.1.4.2 Password Reset**.

Figure 4-26 Web Client Login



- Step 2 The functions and operations of the web client and desktop client are the same. The function introduction and operation guidance, please refer to the relevant contents of the desktop client.

Figure 4-27 Web Client Configuration Interface

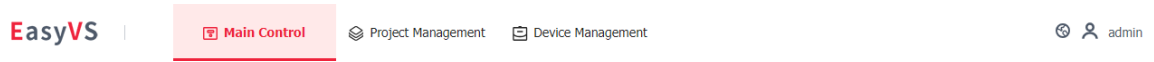


- The default IP address of sensor is 192.168.1.108. Before using the web client, user shall configure the IP address of the PC to make it in the same network segment with the sensor; otherwise, user cannot login the web client of EasyVS.
- User does not need to install any plug-ins on the browser.

# 5 Client Software Layout

After logging in, the home page will be displayed. The menu bar of the configuration interface includes the Main Control, Project Management, Device Management, Language, User Management, Restart, and Logout.

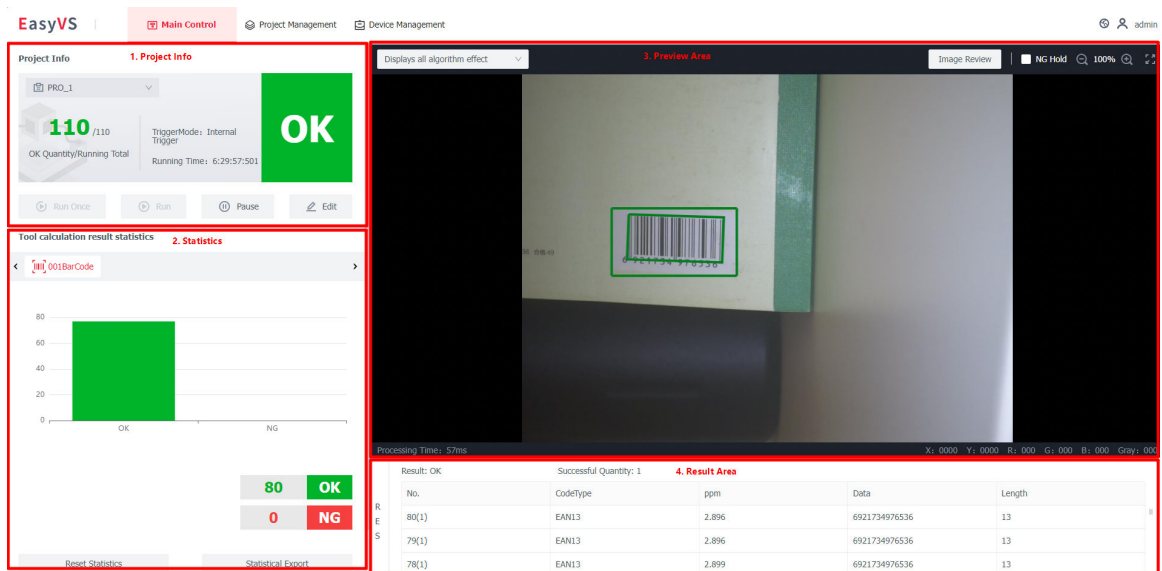
Figure 5-1 Menu Bar



## 5.1 Main Control

The layout of main control includes the project information area, statistics area, preview area, and result area,

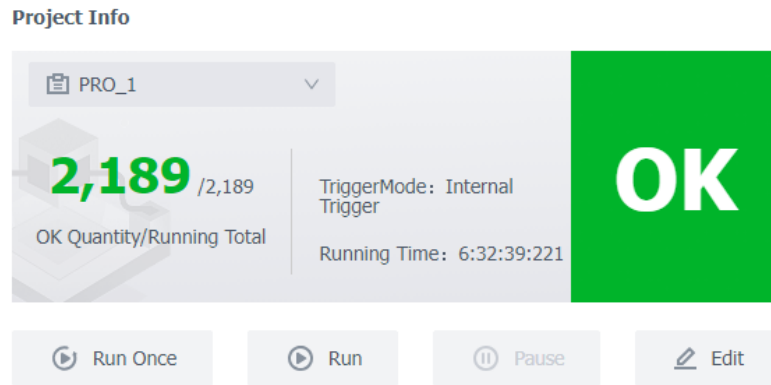
Figure 5-2 Overview



### Project Info

The project information area includes the information of the total amount of projects, trigger mode, and running time. User can click **Pause** to discontinue the project running process, and click the **Run Once** or **Run** to restart the project running process. Click **Edit** to enter the project configuration interface.

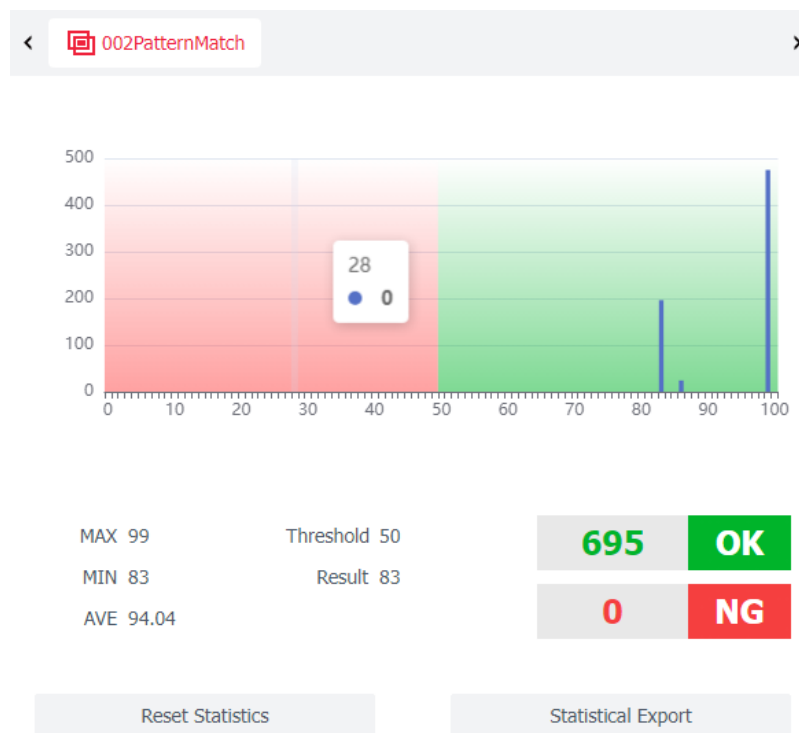
Figure 5-3 Project Info



## Statistics



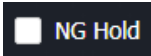



The statistics area displays the running results of each parameter of the project in the form of the histogram. After clicking the **Reset Statistics**, the statistics of running results will be re-calculated. User can click the **Statistical Export** to export the statistics in the form of the txt.

Figure 5-4 Tool Calculation Result Statistics



## Preview Area

Table 5-1 Function Description

No.	Function	Button	Description
1	Display All Algorithm Effect	-	The options include Display All Algorithm Effect, Display Current Algorithm Effect, and Do Not Display Algorithm Effect.
2	Image Review	-	It displays the history records of the algorithm processing effects of the sensor. User can review all of the saved images, or the NG images.
3	Button		Snapshot. Save one frame of image by clicking once.
			Continuous Saving. After clicking it, the client will continuously save the images to the specified folder. User can set the saving path in the <b>Save Image Config</b> . For more details, please refer to the <b>4.1.5 Image Save</b> .
			When there is no any NG image, the client will update the OK images; After the NG result occurs, it will only update the NG images.
			Zoom-in button, it will zoom in the image based on the center of the FoV.
			Zoom-out button, it will zoom out the image based on the center of the FoV.
			Full Screen button. It will display the image in full screen.

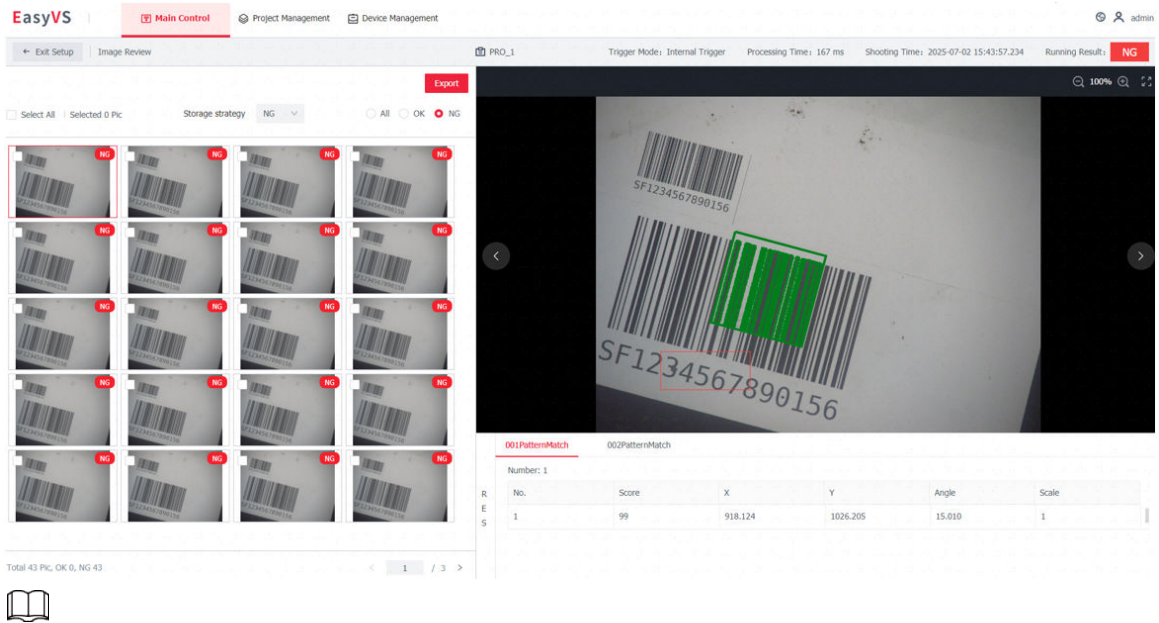
## Result Area

It displays the operation results of the operators. User can select the operator in the statistics area. After selecting the operator, the result area will display the results of the selected operator.

## 5.2 Image Review

When the sensor is running, the history images and operation results are stored in the sensor. The upper limit of image saving quantity may vary depending on the device model, the actual condition shall prevail.

Figure 5-5 Image Review



The images which display in the image review are stored in the sensor, which means that if the sensor restarts or powers off, these images will be lost.

Table 5-2 Function Description

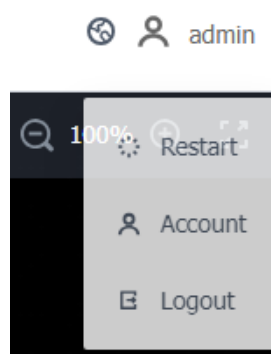
Function	Description
Storage Strategy	<ul style="list-style-type: none"> <li>● NG: The client will save the NG images, and information of NG images.</li> <li>● ALL: The client will save the OK images and NG images, and information of all images.</li> </ul>
Filter	<ul style="list-style-type: none"> <li>● ALL: It will display all of the images.</li> <li>● OK: It will display all of the OK images.</li> <li>● NG: It will display all of the NG images.</li> </ul>
Preview Area	When user clicks the thumbnail images, the preview area will display the selected image, the result area will display the operation result of the selected image. The information bar will display the trigger mode, algorithm processing time, shooting time, and operation result.
Export	It supports the single export and batch export.

## 5.3 User Management

### Procedure

- Step 1** Click the **Admin** in the upper right corner of the configuration interface, and select the **Account** to enter the user management interface.

Figure 5-6 Account



**Step 2** User can modify the password of the administrator account.

Figure 5-7 User Management

Role	Username	Operation
Admin1	admin	

**Step 3** After enabling the **Modify Password** option, user needs to enter the old password and the new password twice. After clicking **OK**, the client will return to the login interface. User must then use the new password to log in.

Figure 5-8 Modify Password

Edit ×

Username:

Role Level:

Modify Password:

Old Password:

New Password:

Confirm Password:

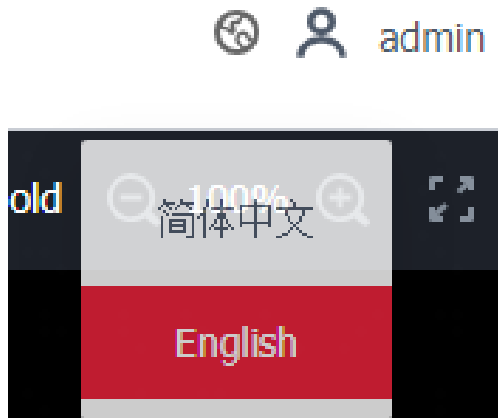


The password length must range from 8 to 32 characters, and the password must contain at least two types of characters, including numbers, uppercase and lowercase letters, and punctuations, excluding ' " ; : and &.

## 5.4 Language

User can click the **Language** to switch the interface language between Chinese and English.

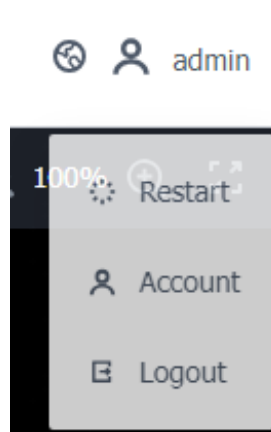
Figure 5-9 Language



## 5.5 Restart and Logout

User can perform the restart and log out in the **Admin**.

Figure 5-10 Restart and Logout



## 6 Set Project

User can enter the Main Control interface to configure the projects. If there is no any project, user can click the **Set Project** to enter the project editing interface, as shown in the figure below. If there is a edited project, user can click **Edit** to enter the configuration interface, as shown in the figure below.

Figure 6-1 No Data

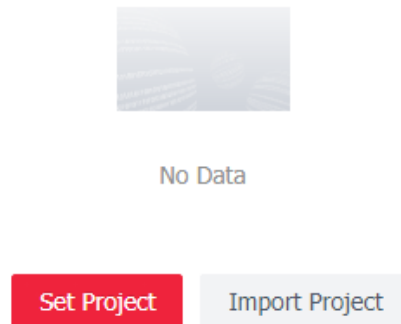
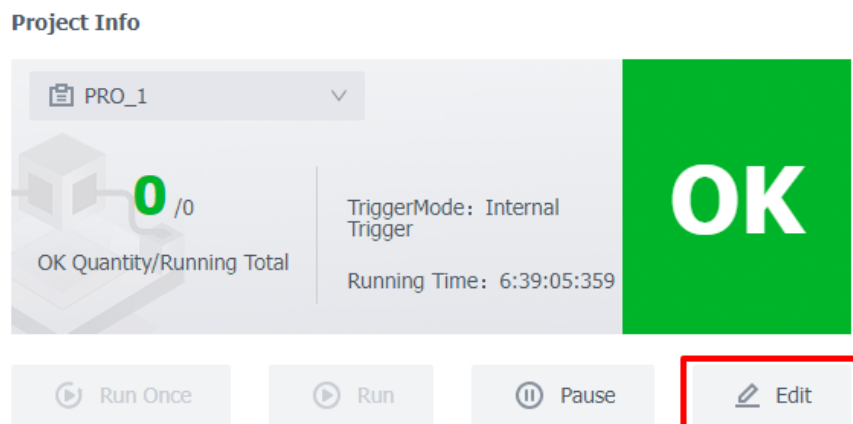


Figure 6-2 Have Project



After entering the project editing interface, user can configure the relevant parameters in the shooting setup, master registration, algorithm setup, and communication setup pages.



User must click the **Save** after completing the parameters configuration; otherwise, the configurations will be lost when user switches the project or restarts the sensor.

Figure 6-3 Save Project

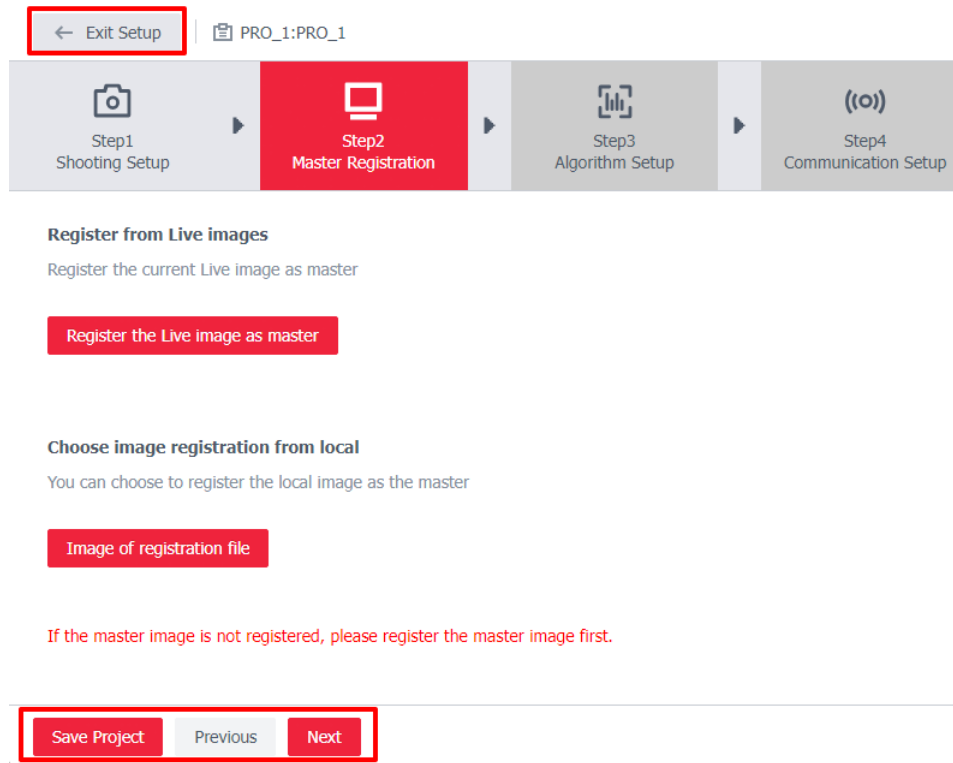


Table 6-1 Function Description

Function	Description
Exit Setup	To return to the main control interface. The unsaved configured parameters take effect temporarily, which means that when user returns to the main control interface, these parameters will be restored to the default values.
Previous	To return to the configuration page of the previous module.
Next	To enter the configuration page of the next module.
Save Project	To save the configured parameters into the project, and return to the main control interface.

## 6.1 Shooting Setup

Click the **Shooting Setup** to enter the **Image Setup** page by default. The **One-Click Configuration** can perform the automatic adjustment of the exposure, white balance, focusing, etc. of the sensor. User can click the Extended Parameters to manually configure the parameters of exposure, focus, light source, mirroring, and image denoising, sharpness, etc.



During the processing of the auto-configuration, user cannot operate the client. Please wait the client completes the configuration.

# Image Setup

Figure 6-4 Parameters in Image Setup (1)

Image Setup
Trigger Setup

▼ Extended Parameters

Exposure

Auto Exposure

Exposure Time(us)

Gain(dB)

Focus

Auto Focus

Focus Position

White Balance

Automatic White Balance ⓘ

R

G

B

Save Project
Next

Table 6-2 Parameter Description

Parameter	Description
Exposure	<p>For adjusting the brightness level of the image. User can perform the <b>Auto Exposure</b>, or manually adjust the <b>Exposure Time</b> and <b>Gain</b>.</p> <p> </p> <ul style="list-style-type: none"> <li>● Increasing the exposure time can enhance the brightness level of the image, but it may also reduce the frame rate to some extent, and when capturing the moving objects, it is prone to motion blur.</li> <li>● Increasing the gain value can enhance the brightness of the image, but it will also increase the image noise to some extent.</li> <li>● During the processing of the auto-exposure, user cannot operate the client. Please wait the client completes the configuration.</li> </ul>
White Balance	<p>For correcting the color of the image. User can perform the Auto White-Balance, or manually adjust the component values of R, G, and B.</p> <p> </p> <ul style="list-style-type: none"> <li>● This function is only available to the color sensor.</li> <li>● We recommend the user adjust the brightness level before adjusting the white balance. When adjusting the white balance, put a pure white object in front of the sensor and cover the half FoV; otherwise, the image color may be distorted after adjusting the white balance.</li> </ul>

Figure 6-5 Parameters in Image Setup (2)

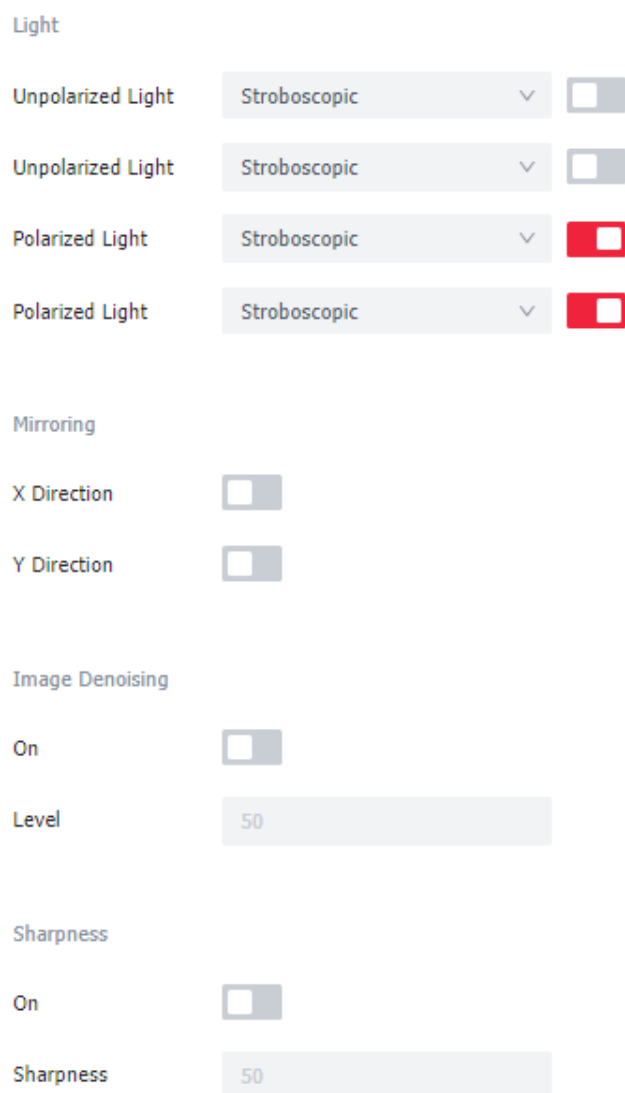


Table 6-3 Parameter Description

Parameter	Description
Light	For setting the parameters of the built-in light sources. The parameters of the light source may vary depending on the device model, and the actual condition shall prevail.
Mirroring	For flipping the image horizontally or vertically.
Image Denoising	For reducing the image noise and increasing the clarity.
Sharpness	For increasing the sharpness of image edges.

Figure 6-6 Trigger Setup

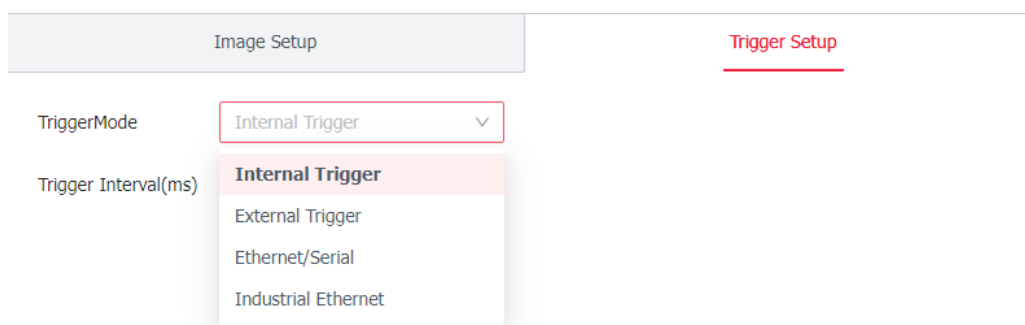




Table 6-4 Parameter Description

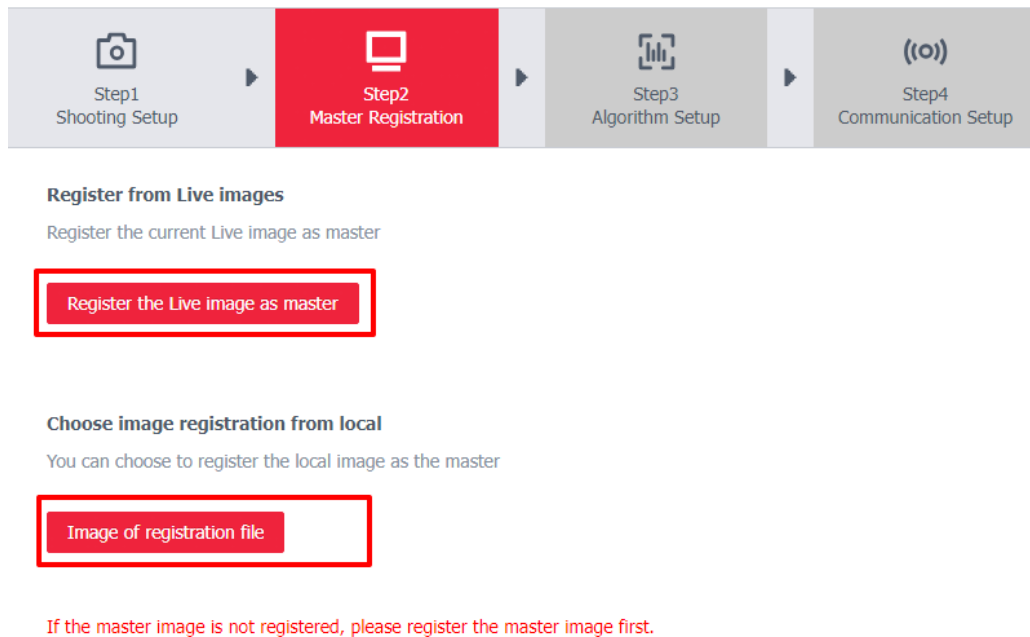
Parameter		Description
Trigger Setup	Internal Trigger	<p>For enabling the continuous image acquiring.</p> <ul style="list-style-type: none"> <li>Trigger Interval (ms): The interval time between each time the sensor acquires an image.</li> </ul> <p> The exposure parameter and working mode of the light source will influence the parameter range of the trigger interval. If user requests a higher frame rate, i.e., lower trigger interval time, user can lower the exposure parameter, or adjust the working mode of the light source.</p>
	External Trigger	<ul style="list-style-type: none"> <li>Signal Delay (ms): To acquire images after a period of time.</li> <li>Signal Buffeting and Buffeting Time (us): When the external trigger signal time is lower than the set buffeting time, the buffeting function will not be triggered, which can avoid the false triggering of this function.</li> <li>Level Flip: When this option is disabled, the trigger mode is low level trigger; when it is enabled, the trigger mode is high level trigger.</li> <li>Trigger Source: The IO characteristics supported by sensor may vary depending on the sensor model, and the actual condition shall prevail.</li> </ul>
	Ethernet/Serial	<p>When the user-defined trigger content is received, the sensor will acquire images. This function is only valid when user completes the settings of communication protocol in the <b>Communication Setup</b>, such as TCP, UDP, serial port.</p> <ul style="list-style-type: none"> <li>Trigger Start Content: When the received content is consistent with the trigger start content, the sensor can be triggered to acquire images.</li> </ul> <p> Only alphanumeric characters and punctuations can be entered. The maximum number of characters is 32.</p>

Parameter		Description
	Industrial Ethernet	The sensor will be triggered to acquire images when it receives the user-defined trigger content. This function is only valid when user completes the settings of industrial communication protocol in the Communication Setup, and completes the configurations of the register address. The industrial protocol includes Profinet, Ethernet/IP, and Modbus Server.

## 6.2 Master Registration

After completing the settings of the Shooting Setup, click Next to enter the page of the Master Registration. The methods of performing the master registration include Register from Live Images and Choose Image Registration from Local.

Figure 6-7 Registration Methods



- Register from Live Images: User can register the selected Live image as the master. Click **Register from Live Images**, the prompt box will pop up, as shown in the figure below. Click OK. The master registration configuration is completed. Note that before performing this function, please ensure the sensor can be streaming normally.

Figure 6-8 Register from Live Images

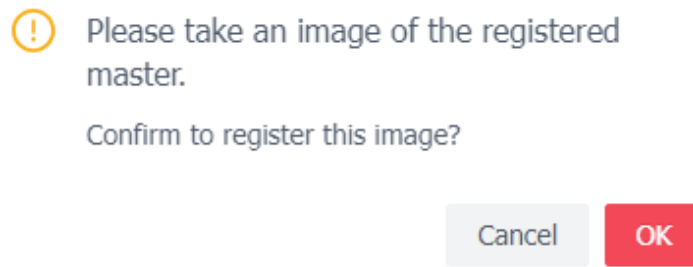
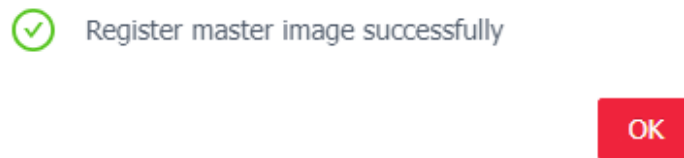
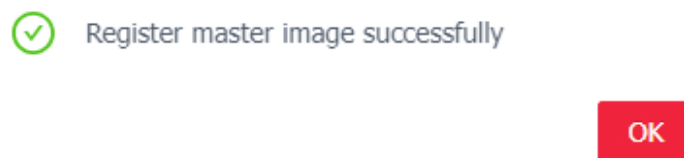


Figure 6-9 Registration Succeeded



- Choose Image Registration from Local: User can register the local image as the master. Click Choose Image Registration from Local, the image selection window will pop up. Note that this function is only valid when the resolution of the local image is consistent with the sensor's. After uploading, the prompt box saying 'Register master image successfully' will pop up.

Figure 6-10 Registration Succeeded



## 6.3 Algorithm Setup

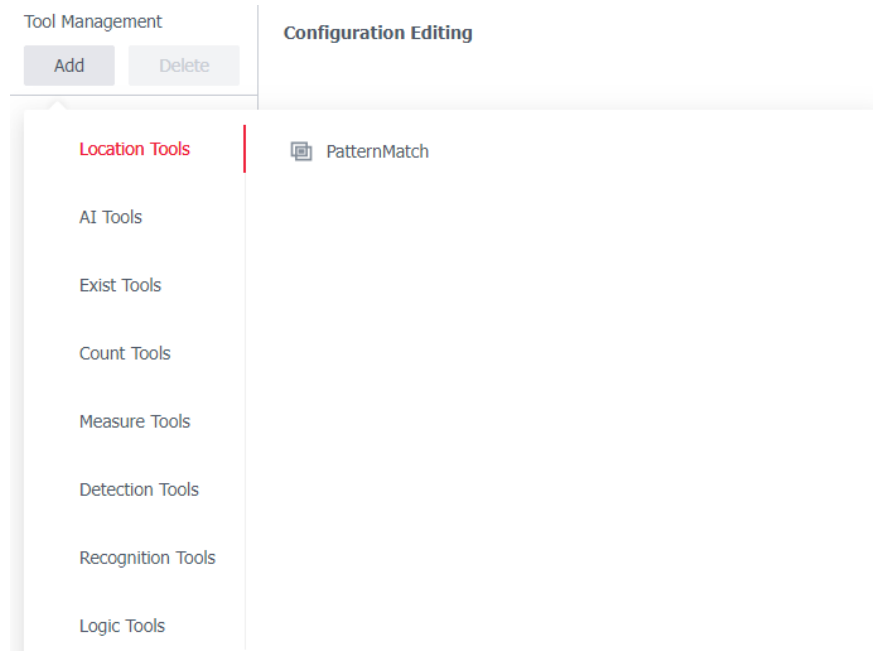
### Procedure

- Step 1 After completing the settings of the **Master Registration**, click **Next** to enter the page of the **Algorithm Setup**. Click **Add** under the **Tool Management** to select the algorithm tool.



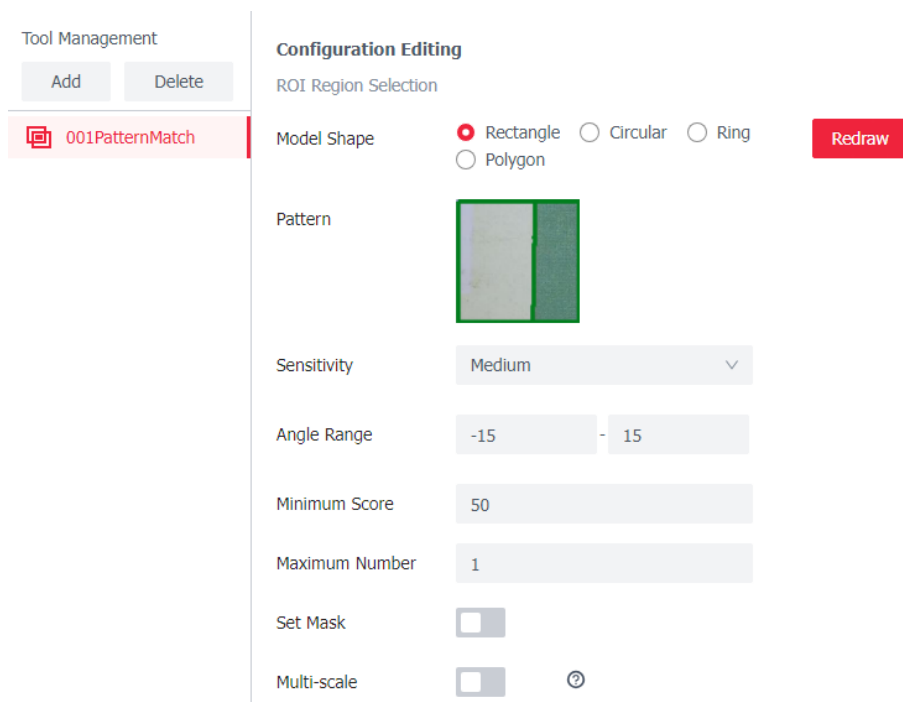
The operator tool supported by the sensor will vary depending on the sensor model, the actual condition shall prevail.

Figure 6-11 Add Operator Tool



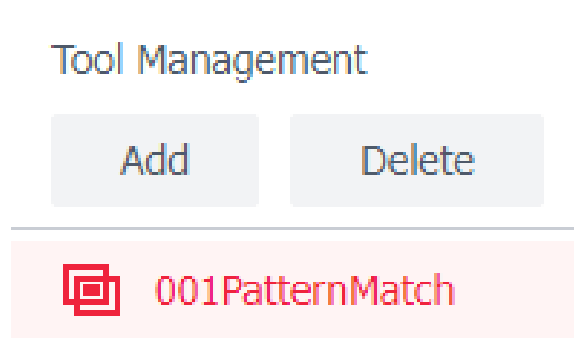
**Step 2** After completing the operator tool addition, the configuration interface will be displayed. Take the operator tool of Pattern Match as an example.

Figure 6-12 Configuration Editing



**Step 3** User can delete the selected operator tool.

Figure 6-13 Delete Operator Tool



In the Tool Management, user can add multiple same operator tool, and the upper limit of the number of operator tool is 16. When user adds the 17th operator tool in the list, the prompt box saying 'The number of modules has reached the upper limit' will pop up. As for the operator tools that may occupy a lot of resources, the upper limit number of operator tool will be less than the general number, and the prompt box will also pop up, for example, pattern match, contour compare, and color recognition.

## 6.4 I/O and Communication Setup

User can configure the parameters of I/O in the I/O Setup page included in the Communication Setup.

### 6.4.1 I/O Setup

When the sensor meets the requirements of result output, the sensor will output the opto-isolated signals to the external system. The I/O output configuration may vary depending on the sensor model, the actual condition shall prevail.

Figure 6-14 Pulse Signal Output

▼ Optocoupler Outputline0

Output Condition	ProjectNG	▼
Output Delay	0	ms
Output Signal Type	Pulse Signal	▼
Pulse Width	30	ms
Level Flip	<input type="checkbox"/>	Default High Level Takes Effect

Table 6-5 Parameter Description

Parameter	Description
Output Condition	To set the status of the project or operator tool as the requirement of the I/O signal output.
Output Delay	To set the delay time value of I/O signal output.
Output Signal Type	It includes the pulse signal and periodic signal. <ul style="list-style-type: none"> <li>• When it is set to the pulse signal, user should also set the pulse width.</li> <li>• When it is set to the periodic signal, user should also set the signal duty cycle, signal cycle, and signal cycle count.</li> </ul>
Level Flip	After enabling the level flip function, it will be the low level; otherwise, it is high level.

Figure 6-15 Periodic Signal

▼ Optocoupler Outputline0

Output Condition  ▼

Output Delay  ms

Output Signal Type  ▼

Signal Duty Cycle

Signal Cycle  ms

Signal Cycle Count

Level Flip  Default High Level Takes Effect

For the I/O ports needs to be reused, enable the I/O Transformation, and set the parameters of the I/O output port.

Figure 6-16 Reused I/O Output Parameters

The screenshot shows a configuration page for I/O Output Parameters. The 'IOtransformation' checkbox is checked and highlighted with a red box. Below it are several settings: 'Output Condition' is set to 'ProjectNG', 'Output Delay' is '0 ms', 'Output Signal Type' is 'Pulse Signal', 'Pulse Width' is '30 ms', and 'Level Flip' is unchecked with the text 'Default High Level Takes Effect'.

IOtransformation	<input checked="" type="checkbox"/>
Output Condition	ProjectNG
Output Delay	0 ms
Output Signal Type	Pulse Signal
Pulse Width	30 ms
Level Flip	<input type="checkbox"/> Default High Level Takes Effect

## 6.4.2 Communication Setup

User can add or delete the communication protocol in the Communication Setup page.

Figure 6-17 Protocol List

The screenshot shows the 'IO Setup' page with the 'Communication Setup' tab selected. The 'Protocol List' section has 'Add' and 'Delete' buttons. A dropdown menu is open, showing a list of protocols with radio buttons: Ethernet (TCP Client, TCP Server, UDP), Industrial Protocol (ModbusServer, Profinet, EtherNet/IP), Serial Port (Serial Port), and FTP (FTP).

IO Setup		Communication Setup
Protocol List	Configuration Editing	
Add	Delete	
Ethernet		
<input type="radio"/> TCP Client	<input type="radio"/> TCP Server	<input type="radio"/> UDP
Industrial Protocol		
<input type="radio"/> ModbusServer	<input type="radio"/> Profinet	<input type="radio"/> EtherNet/IP
Serial Port		
<input type="radio"/> Serial Port		
FTP		
<input type="radio"/> FTP		

After adding the protocol, the client will display the relevant parameters of the selected protocol. Take the TCP Client as an example.

Figure 6-18 TCP Client Configuration

IO Setup

---

Protocol List

Add
Delete

TCPClient

Communication Setup

---

**Configuration Editing**

Parameters

Server IP

Port

Communication Content

Format Input String

No.	Name	Content	Operation
1	None <span style="font-size: 0.8em;">▼</span>	Please Input String	+ <span style="font-size: 0.8em;">🗑️</span>

Format Output String

No.	Name	Data Type	Operation
1	None <span style="font-size: 0.8em;">▼</span>		+ <span style="font-size: 0.8em;">📄</span> <span style="font-size: 0.8em;">📄</span> <span style="font-size: 0.8em;">🗑️</span>

Data Format

Start String	#
--------------	---

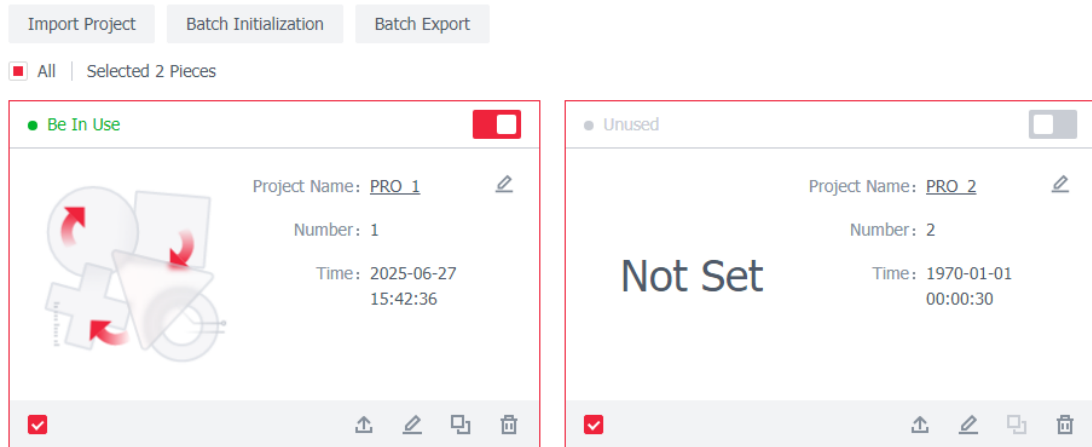


User can add only one protocol of the same type. For example, user can choose only one from the TCP Client, TCP Server, and UDP protocols.

# 7 Project Management

User can operate the project one by one, or in batch. Click **All** or select the projects by clicking the icon in the bottom left corner of each project to manage and operate them in batch, such as batch export, and batch initialization.

Figure 7-1 Manage Projects in Batch



User can perform the project import, project switch, name modification, project export, project setting, project copy, or project initialization.



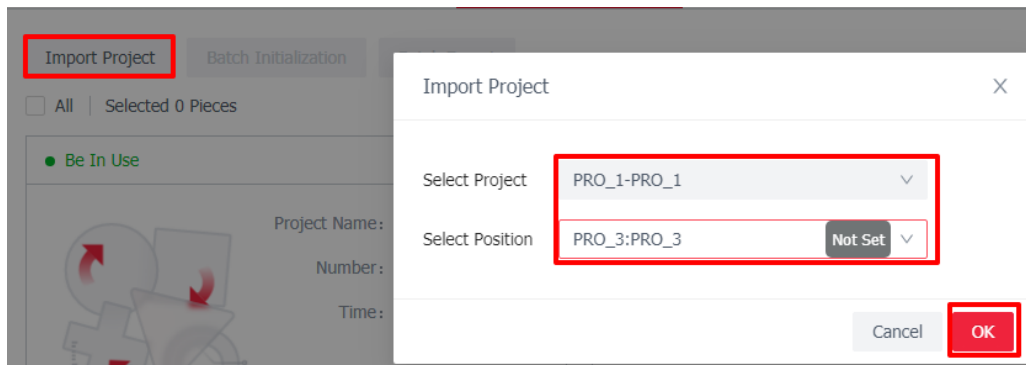
User can create up to 32 projects in the project management page.

## Import Project

Select the project file with the suffix name of '.pro'. After completing the file selection, the configuration window will pop up.

- Select Project: To select a project file which needs to be imported.
- Select Position: To define which project the file needs to import.

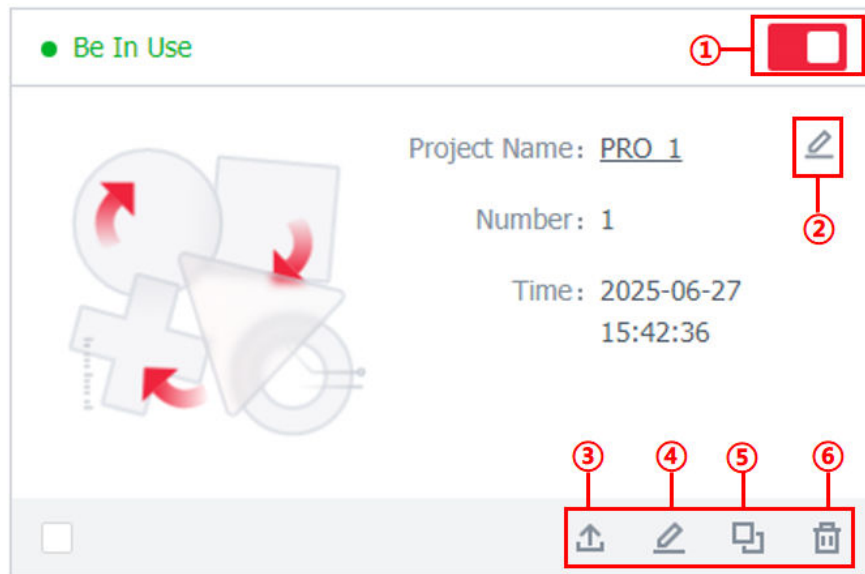
Figure 7-2 Import Project



## Switch Project

User can enable the project by clicking the button marked with ①, and the client will automatically disable the original project. Also, user can switch projects in the **Main Control** page, or switch projects by setting the communication command.

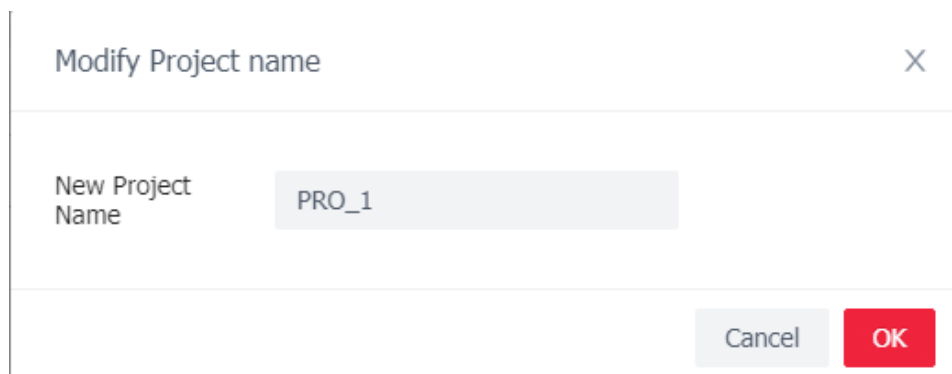
Figure 7-3 Manage Project



## Modify project name

Click icon marked with ② to modify the project name.

Figure 7-4 Modify Project Name



## Export Project

Click icon marked with ③ to export the project.

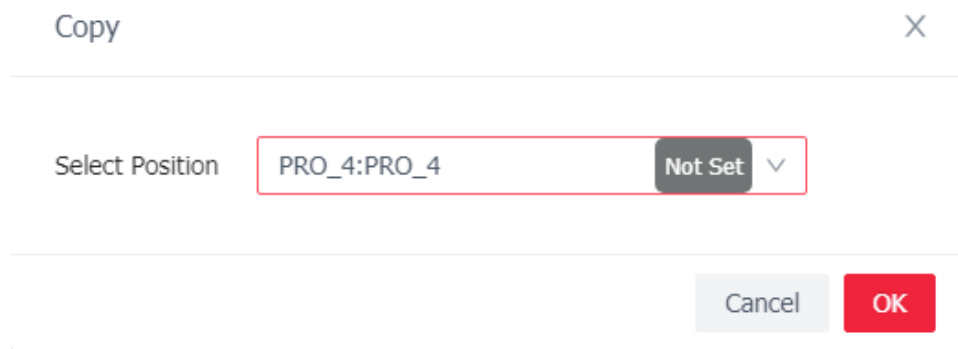
## Set Project

Click icon marked with ④ to enter the project configuration interface.

## Copy Project

Click icon marked with ⑤ , the configuration window will pop up. User should select the project to save the copied parameters.

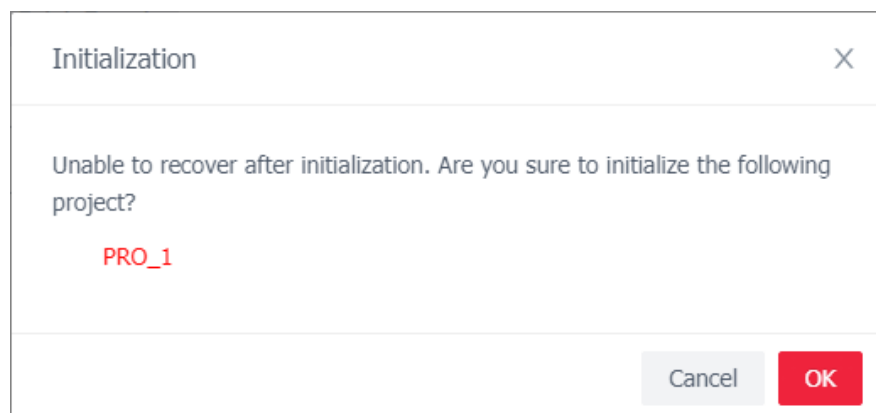
Figure 7-5 Copy project



## Project Initialization

Click icon marked with ⑥, the confirmation prompt box will pop up, click **OK** to start the initialization.

Figure 7-6 Project Initialization



# 8 Device Management

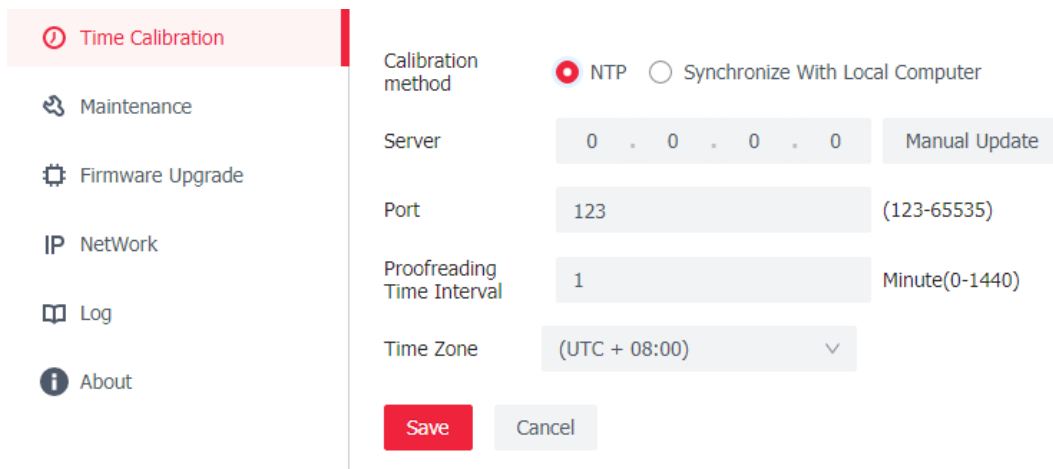
The functions in the Device Management include time calibration, maintenance, firmware upgrade, network setting, Log export, etc.

## 8.1 Time Calibration

The calibration methods include **NTP** and **Synchronize with Local Computer**.

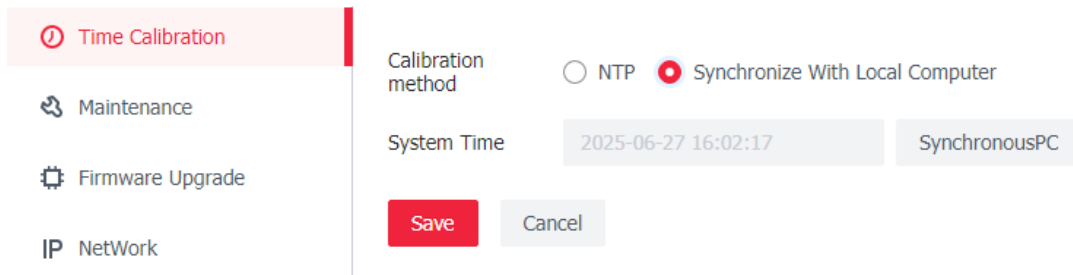
After selecting the **NTP**, configure the IP address in the **Server**, port number in the **Port**, **Proofreading Time Interval**, and **Time Zone**. Click **Save**.

Figure 8-1 NTP



After selecting the **Synchronize with Local Computer**, click the **SynchronousPC**.

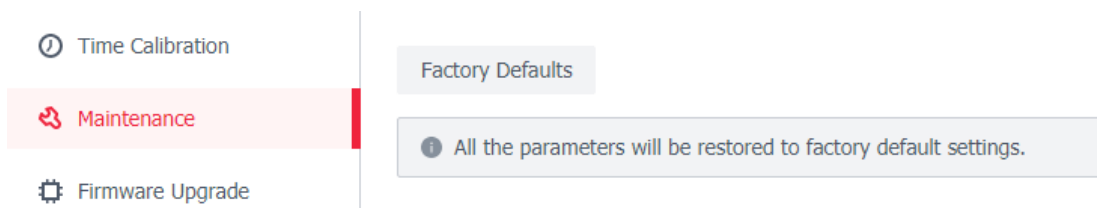
Figure 8-2 Synchronize with Local Computer



## 8.2 Maintenance

After clicking the Factory Defaults, the client software will restore the parameters of the sensor.

Figure 8-3 Factory Defaults



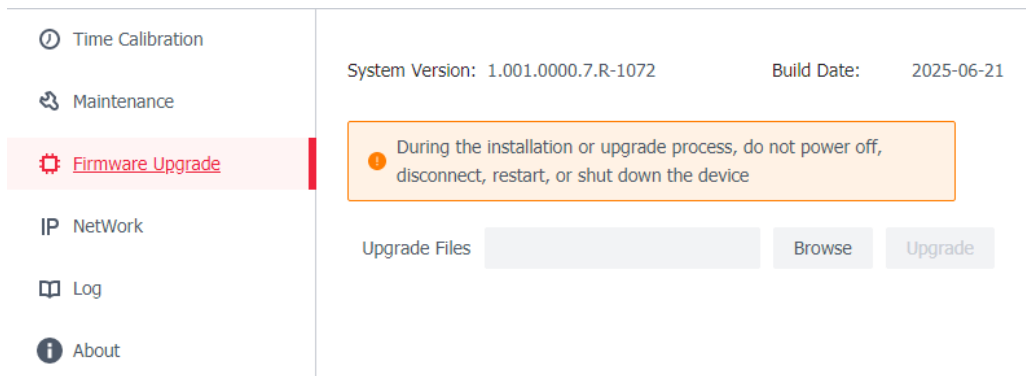


The IP address of the sensor will be restored to 192.168.1.108 The sensor will restart.

## 8.3 Firmware Upgrade

In the Firmware Upgrade page, it will display the system version information and build date information. Click **Browse** to select and upload the firmware file with the suffix of the '.bin', and click **Upgrade** to perform the firmware upgrading. The firmware upgrading will take a while, please wait patiently.

Figure 8-4 Firmware Upgrade

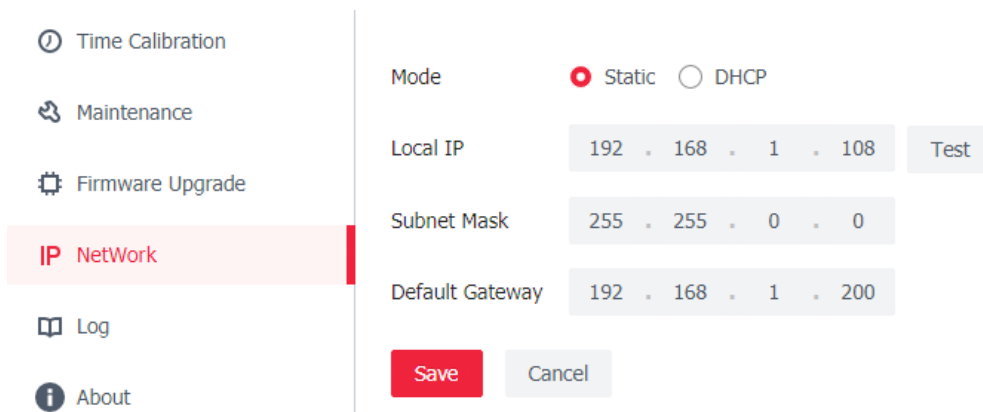


Do not disconnect the power supply and network connection during the upgrading. Do not restart or shut down the device when upgrading firmware.

## 8.4 Network

The working mode of the network includes **Static** and **DHCP**. User can click the **Test** in the right side of the **Local IP** to test the entered static IP address.

Figure 8-5 Set IP Address



## 8.5 Log

User can search the operation logs according to the date. Also, user can clear the logs and export logs in batch.

Figure 8-6 Search Logs

No.	Level	Type	Time	Username	Operation
1	Info	ImageReview	2025-07-02 15:45:22	admin	🗑️
2	Info	ImageReview	2025-07-02 15:43:58	admin	🗑️
3	Info	page Switch	2025-07-02 15:43:44	admin	🗑️
4	Info	SaveProject	2025-07-02 15:43:43	admin	🗑️

## 8.6 About

The About page include the information of the system version, build date, and web version.

Figure 8-7 About

System Version: 1.001.0000.7.R-1072      Build Date: 2025-06-21

Web Version: V3.2.1.381161



If there are any abnormal devices that user needs to have checked by the manufacturer, please provide the device information, including model, firmware version, and serial number, to the sales manager or technical specialist.

# 9 Operator Tools

## 9.1 Location Tools

The **Location Tools** now supports the **Pattern Match**, which performs the detection by using the positioning techniques.

### Pattern Match

This operator adopts the technique of feature matching to assist the positioning and correct the location of the moving object.

### Procedure

1. Draw the pattern area. It supports the rectangle, circular, ring, and polygon. The pattern marked with ② in the figure below can be moved and scaling.

Figure 9-1 Draw Pattern Area

#### Configuration Editing

##### ROI Region Selection

Model Shape

- Rectangle    Circular    Ring  
 Polygon

Redraw

Pattern



Figure 9-2 Pattern Area




2. If there are noises in the pattern area, user can enable the **Set Mask**. Select the shape to define the shielding area on the image. The shapes include rectangle, polygon, and circle. User can add and delete multiple shapes.

Figure 9-3 Set Mask

**Configuration Editing**

ROI Region Selection

Model Shape  Rectangle  Circular  Ring  Polygon Redraw

Pattern 

Sensitivity  v

Angle Range  -

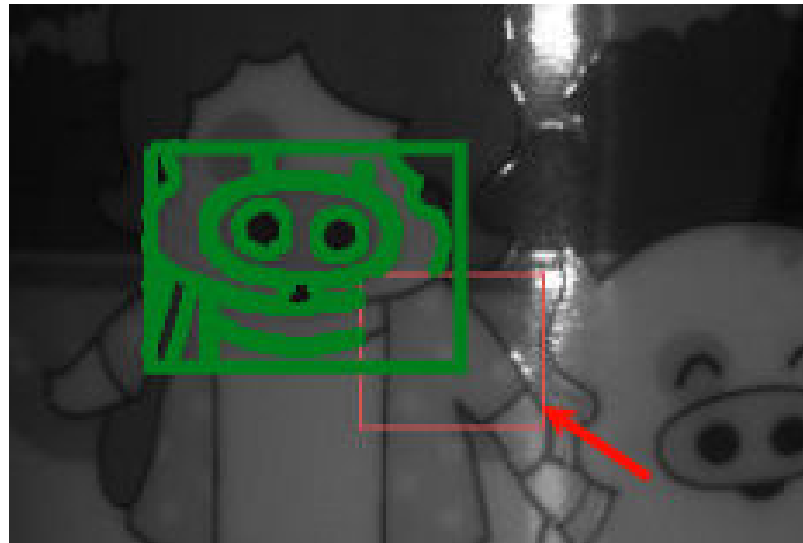
Minimum Score

Maximum Number

**Set Mask**

Multi-scale  ?

Figure 9-4 Shielding Results



3. The sensitivity level includes high, medium, and low. The higher the sensitivity, the more feature points are extracted. The sensitivity level should be set according to the actual conditions, the noises could be mistakenly extracted as the feature points, and this will increase the running time of the algorithm process.

Figure 9-5 Sensitivity

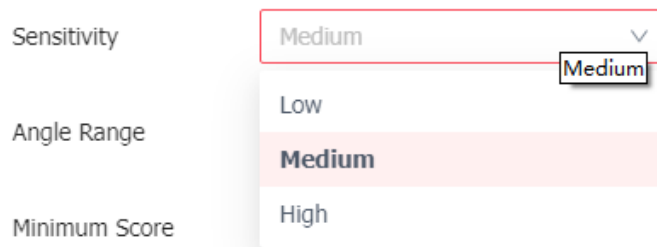
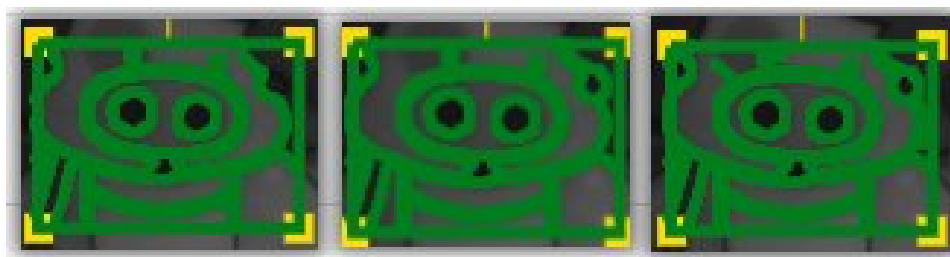
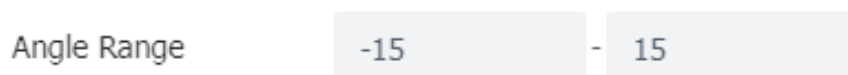


Figure 9-6 Post Processing Effect (Low/Medium/High)



4. Draw the search area. The rectangle marked with ② in the figure 9-2 is the search area.
5. Set the values of the **Angle Range**. The algorithm will recognize and match the object if its angle changing is in the set range. If the angle exceeds the set range, the algorithm cannot recognize the object. Therefore, the larger the angle range, the greater the allowable range of angle variation will be, and the longer the processing time of the algorithm is.

Figure 9-7 Angle Range



- Set the similarity threshold between the target and the pattern. The higher the score, the higher the similarity. The object can only be recognized when the similarity score of the matched objects is higher the set minimum score.

Figure 9-8 Minimum Score

Minimum Score

- Set the maximum number of the object.

Figure 9-9 Maximum Number

Maximum Number



When the maximum number is not 1, the operator of the pattern match can be user as the counter.

- When the Multi-Scale is disabled, the algorithm will match the objects by comparing the object and pattern in a ratio of 1:1. After enabling the Multi-Scale, the operator can also recognize and match the object with the different height in the FoV of sensor, but this function will increase the processing time. Enable this function according to the actual condition.

Figure 9-10 Multi-scale

Multi-scale  ?



When using the operator of Pattern Match as the datum of positioning, the pattern user selects in the image should be with clear edges and unique feature. If the edges of pattern are not clear and with noises, the operator cannot match the pattern and object; if the features of pattern is not unique, the matching results will be different and wrong.

Figure 9-11 Edges with Noises

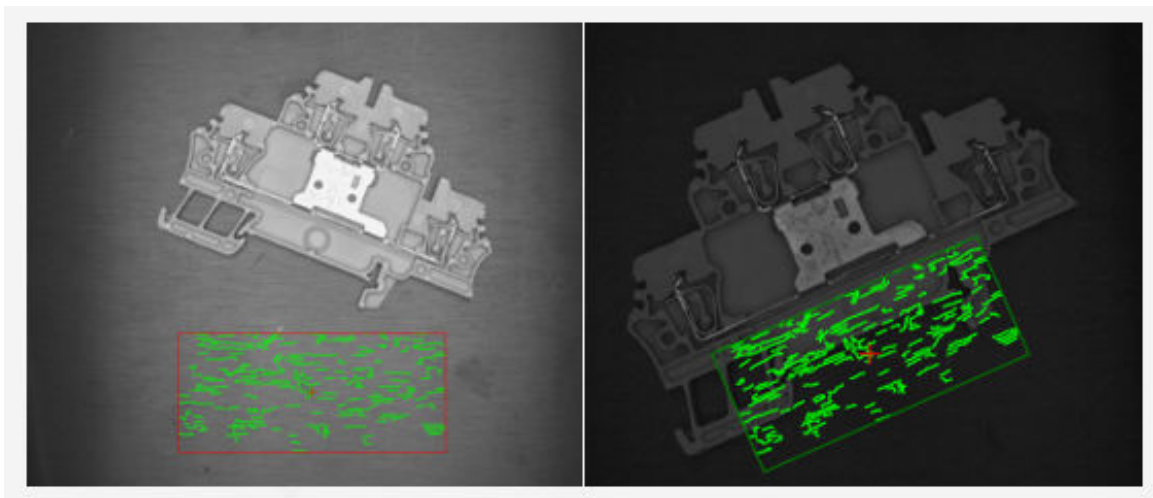
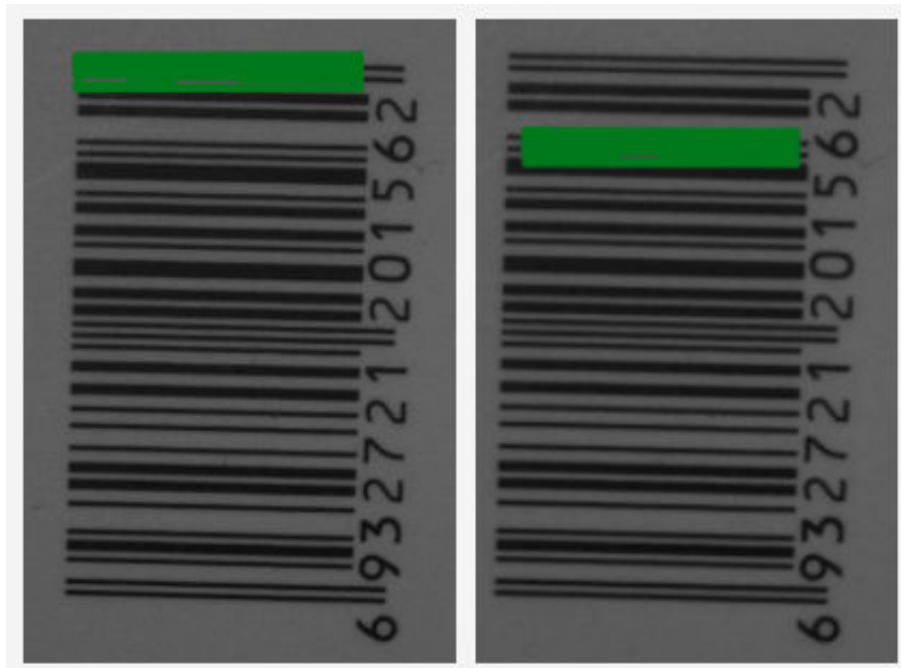


Figure 9-12 Not Unique Feature



## 9.2 AI Tools

The AI Tools now supports the AI Classification operator which uses the AI module to perform the tasks processing.

### AI Classification

AI classification automatically divides the image, area, or pixels in the image into the specific categories by analyzing their features using the deep-learning algorithm. The object discrimination capability of this operator can greatly improve the automation efficiency without any additional manual intervention.

### Procedure

1. Select the image source. It includes the **Camera Real-Time** and **Local Upload**.

Figure 9-13 Image Source

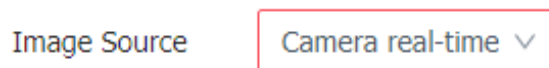


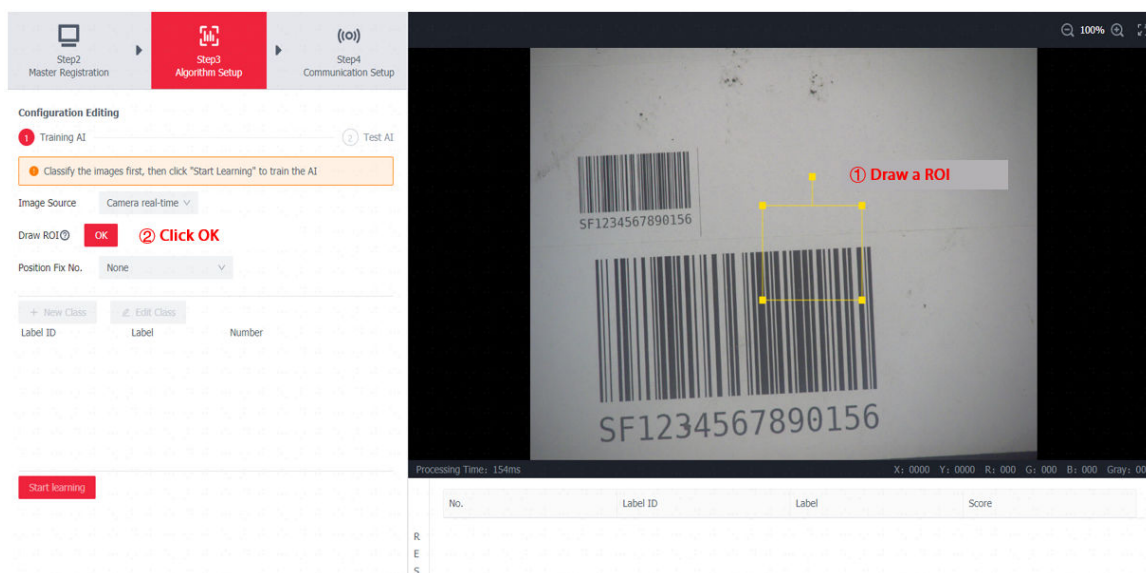
Figure 9-14 Import Image



The AI Classification operator only supports the images that resolution is consistent with the sensor's, and user can upload multiple images.

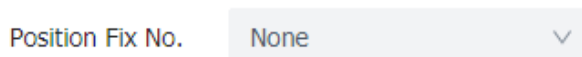
2. Draw the ROI area on the image, and click **OK**. The ROI box size will be locked and can only be moved and rotated.

Figure 9-15 Draw ROI



3. Set **Position Fix No.** Select the **Pattern Match** operator that needs to be bound. When it is running, the operator will correct the location of the ROI box according to the offset recognized by the bound pattern match operator.

Figure 9-16 Position Fix No.

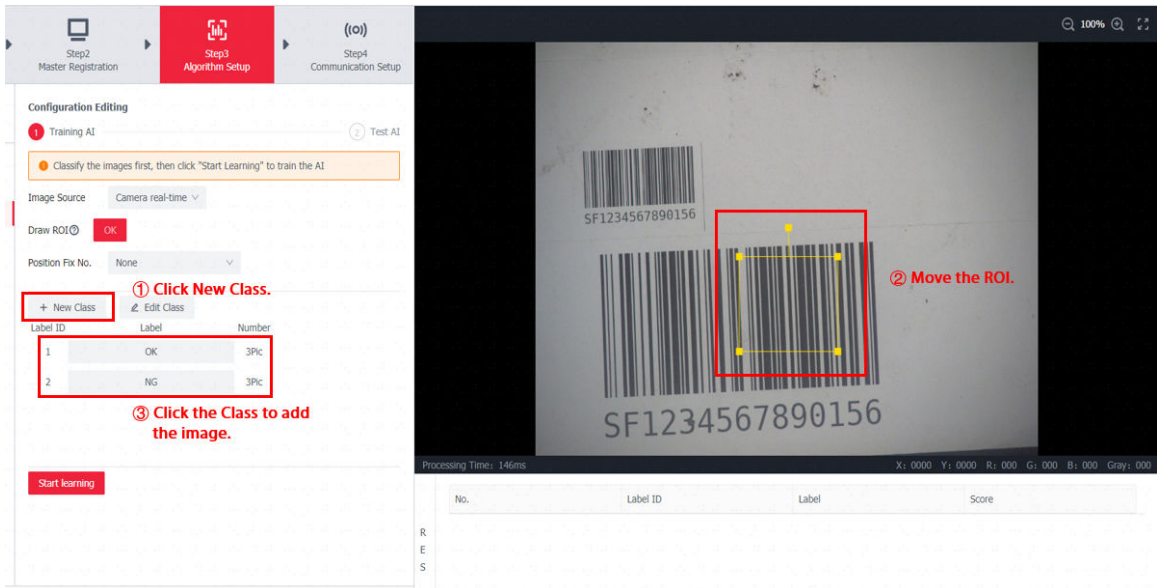




After selecting the Camera Real-time and binding the operator of pattern match, the operator will also correct the location of the ROI according to bound operator of the pattern match in the configuration interface.

4. Add and edit the class. Click **New Class**, and enter the label name. User can add multiple classifications in the AI Classification operator. Move the ROI box drawn in the second step, and click the added label. The image captured by the ROI box will be added into the selected label. Click **Edit Class** to rename, delete, or move the added labels and images.

Figure 9-17 New Class and Edit Class



5. Click **Start Learning**.

Figure 9-18 Start Learning

### Configuration Editing

① Training AI ————— ② Test AI

① Classify the images first, then click "Start Learning" to train the AI

Image Source Camera real-time ▾

Draw ROI ⓘ OK

Position Fix No. None ▾

+ New Class

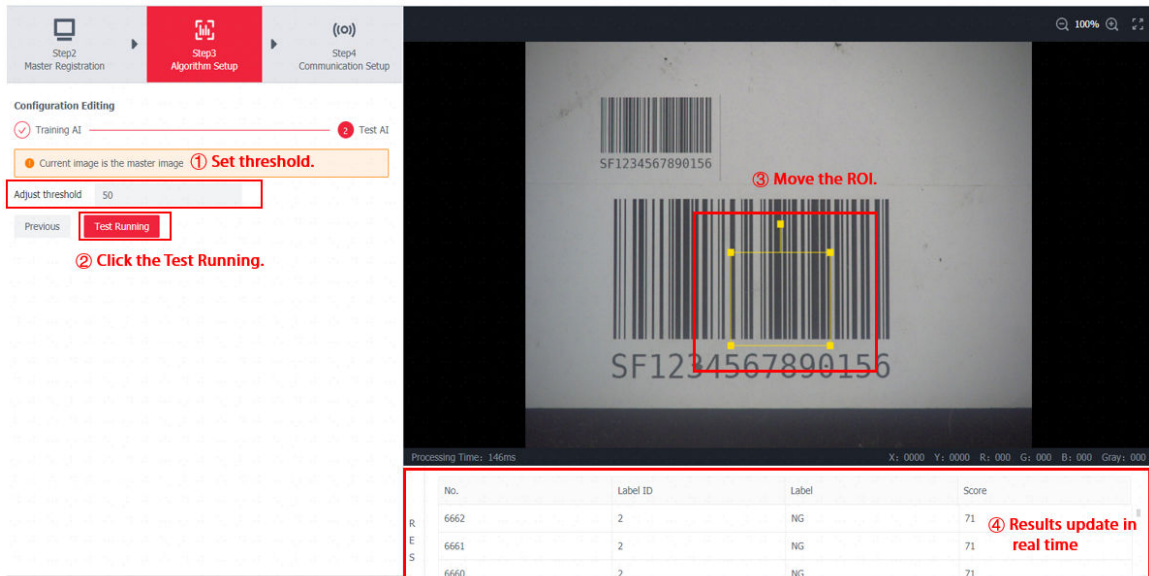
✎ Edit Class

Label ID	Label	Number
1	QR	3Pic
2	DM	3Pic
3	Barcode	3Pic

Start learning

6. Test the model processing effect. Click **Next**, and drag the ROI box to test the model processing effect on the master image. Click **Test Running** to perform the classification processing effect on the streaming images in real time.
  - **Adjust Threshold:** To set the threshold of the classifications recognized by the operator. If the score is greater than the threshold, the status of operator will be OK, otherwise, it is NG.

Figure 9-19 Model Testing Effect



## 9.3 Exist Tools

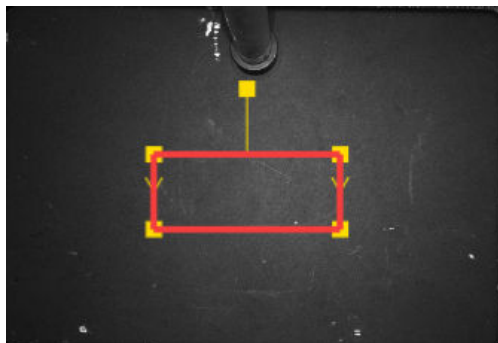
### 9.3.1 Find Line

The Find Line operator is for detecting whether the image contains the straight line. The operator finds the edge points of the object in the image, links these points, and judges whether the lines in the image are straight according to the straightness.

#### Procedure

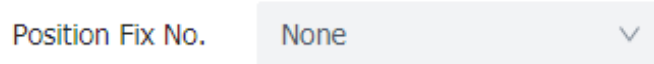
- Step 1** User can drag the ROI box or adjust its size in the under-detection area according to the actual demands. When the ROI box is red, it is NG; when the ROI box is green, it is OK.

Figure 9-20 Draw ROI Box



Step 2 Set **Position Fix No.** Select the Pattern Match operator that needs to be bound. When it is running, the operator will correct the location of the ROI box according to the offset recognized by the bound pattern match operator.

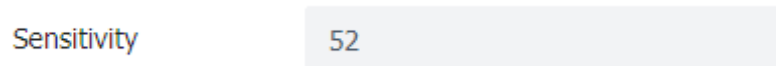
Figure 9-21 Position Fix No.



Step 3 Set **Sensitivity.** The sensitivity of the straight-line detection, that is, the ability to correctly identify the straight lines or exclude the nonlinear lines under the different conditions. The higher the value, the lower the grey difference requirement to the object edges in the image.

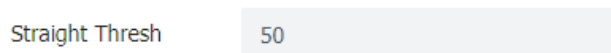
- Range: 0~100.

Figure 9-22 Sensitivity



Step 4 Set **Straight Thresh.** When the fitting score is greater than the set value, the status of operator is OK, otherwise, it is NG.

Figure 9-23 Straight Thresh



Step 5 If there are any non-detection areas needs to be shielded in the ROI area, user can enable the **Set Mask.** Select the shape to define the shielding area on the image. The shapes include rectangle, polygon, and circle. User can add and delete multiple shapes.

Figure 9-24 Set Mask

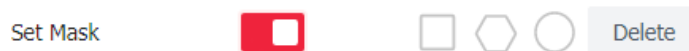
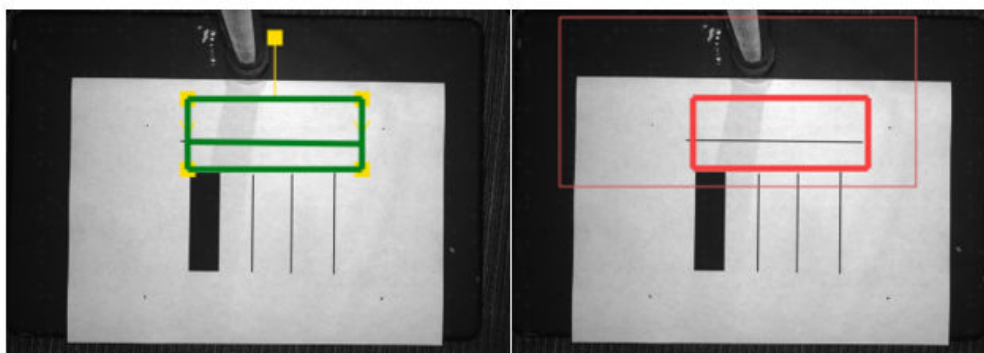


Figure 9-25 Shielding Results



- The search direction of the polarity is the direction of the arrow on the ROI box.
- The high sensitivity will recognize the weaker edge points to link them as the straight line.
- The low sensitivity can only recognize the more obvious edge points to link them as the straight line.

- The straightness parameter is for measuring the approximation degree between the detected line or edges and straight line.

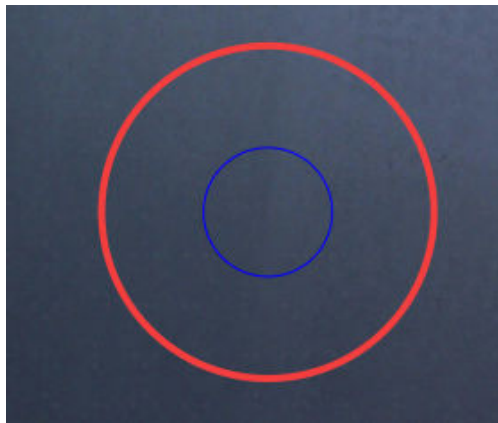
## 9.3.2 Find Circle

The Find Circle operator is for detecting whether the image contains the circular objects. The operator finds the edge points of the object in the image, links these points to a circle, and judges whether the object is circular in the image according to the roundness of the linked circle.

### Procedure

- Step 1 User can drag the ROI box or adjust its size in the under-detection area according to the actual demands. The ROI in the Find Circle operator has two circles, including inner circle and outer circle. User can click on the area in the inner circle to select the inner circle and adjust the inner circle size; click on the area between the inner circle and outer circle to select the outer circle. When the outer circle is red, it is NG; when the outer circle is green, it is OK.

Figure 9-26 Circular ROI



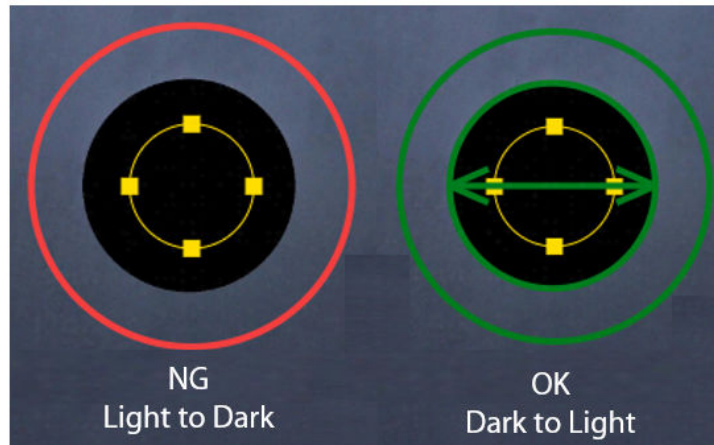
- Step 2 Set **Character Polarity**.

- From Dark to Light: It will find the circular edges which have the dark to light.
- From Light to Dark: It will find the circular edges which have the light to dark.
- Any Polarity: It will find the circular edges which have the light to dark or dark to light.



The search direction of the polarity is from inner circle to outer circle.

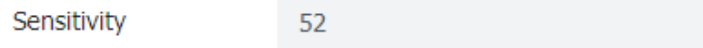
Figure 9-27 Search Direction



Step 3 Set **Position Fix No.** Select the Pattern Match operator that needs to be bound. When it is running, the operator will correct the location of the ROI box according to the offset recognized by the bound pattern match operator.

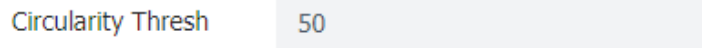
Step 4 Set **Sensitivity.** The higher the value of sensitivity, the lower the requirements to the grey difference of the object edges in the image.

Figure 9-28 Sensitivity



Step 5 Set **Circularity Thresh** to define the recognition threshold. If the recognition score is greater than the threshold, the status of operator will be OK, otherwise, it is NG.

Figure 9-29 Circularity Thresh

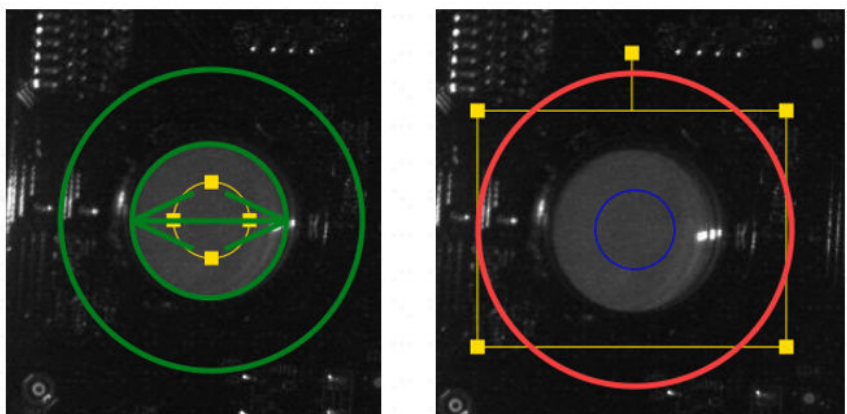


Step 6 If there are any non-detection areas needs to be shielded in the ROI area, user can enable the **Set Mask.** Select the shape to define the shielding area on the image. The shapes include rectangle and polygon. User can add and delete the multiple shapes.

Figure 9-30 Set Mask



Figure 9-31 Shielding Results



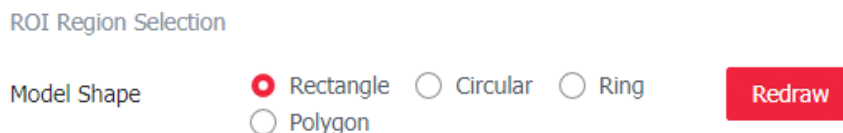
### 9.3.3 Blob Exist

The Blob Exist operator is for detecting and positioning the area which is in the set grayscale range, or cannot be measured. The Blob Exist can position and judge the blobs and shapes in the image.

#### Procedure

- Step 1 Draw the ROI. It supports the rectangle, circular, ring, and polygon. User can move the ROI or adjust its size.

Figure 9-32 Draw ROI

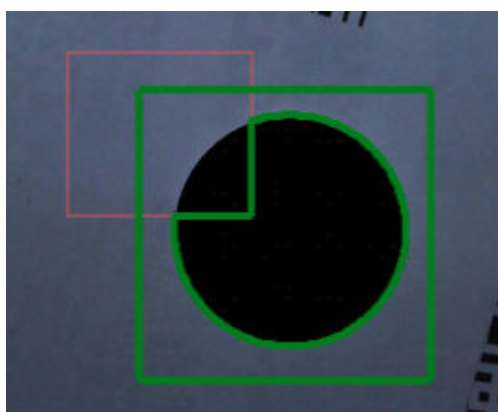


- Step 2 If there are any non-detection areas needs to be shielded in the ROI area, user can enable the **Set Mask**. Select the shape to define the shielding area on the image. The shapes include rectangle, polygon, and circle. User can add and delete the multiple shapes.

Figure 9-33 Set Mask



Figure 9-34 Shielding Results



Step 3 Set **Grayscale Threshold**. The grayscale threshold is for separating the target blobs and background, so as to identify and count the number of the blobs accurately. The Blob Exist operator will detect the blobs which are in the set range of the grayscale threshold.

Figure 9-35 Grayscale Threshold

Grayscale Threshold 100 - 150

Step 4 Set **Area Range**. User can set the Area Range to make the operator ignore the too large and too small blobs.

Figure 9-36 Area Range

Area Range 1 - 9999999

Step 5 Set **Position Fix No.** Select the Pattern Match operator that needs to be bound. When it is running, the operator will correct the location of the ROI box according to the offset recognized by the bound pattern match operator.

Figure 9-37 Position Fix No.

Position Fix No. None

Step 6 Set **Judging Conditions**. When selecting the Existence OK, the status will be OK when operator finds the blobs in the image; when selecting the Non-Existent OK, the status will be OK when operator does not find the blobs in the image.

Figure 9-38 Judging Conditions

Judging Conditions Existence OK



The Blob Exist operator can only output result of one blob in the image, even though the operator finds multiple blobs in the image. If user requests to detect multiple blobs, please use the Blob Count operator.

## 9.4 Count Tools

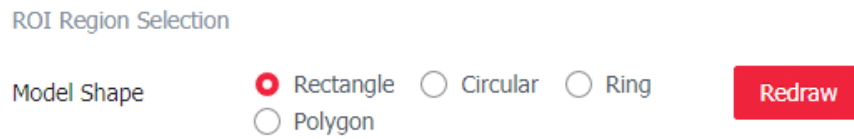
### Blob Count

The Blob Count operator is for automatically identifying and counting the specific areas, such as particles, defects, etc. The operator first finds the blobs which meet the preset conditions, then counts the blobs, and finally screens out the targets that meet the size requirements which are set according to the actual demands.

### Procedure

1. Draw the ROI. It supports the rectangle, circular, ring, and polygon. User can move the ROI or adjust its size.

Figure 9-39 Draw ROI

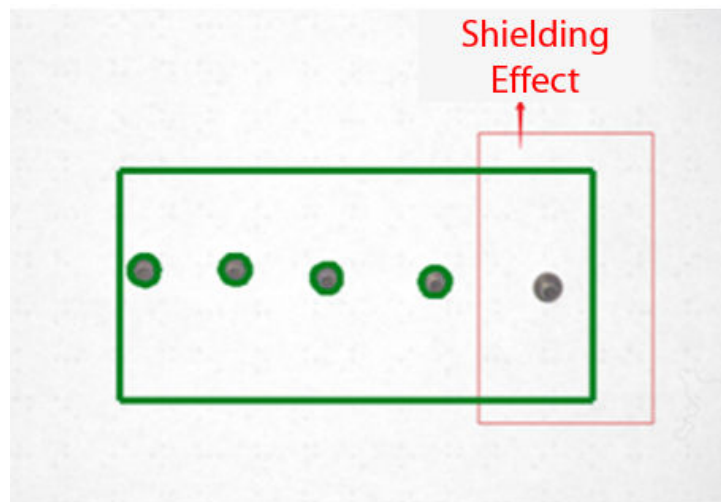


2. If there are any non-detection areas needs to be shielded in the ROI area, user can enable the **Set Mask**. Select the shape to define the shielding area on the image. The shapes include rectangle, polygon, and circle. User can add and delete multiple shapes.

Figure 9-40 Set Mask

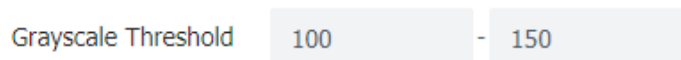


Figure 9-41 Shielding Results



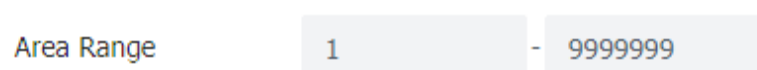
3. Set **Grayscale Threshold**. The grayscale threshold is for separating the target blobs and background, so as to identify and count the number of the blobs accurately. The Blob Count operator will detect the blobs which are in the set range of the grayscale threshold.

Figure 9-42 Grayscale Threshold



4. Set **Area Range**. User can set the Area Range to make the operator ignore the too large and too small blobs.

Figure 9-43 Area Range



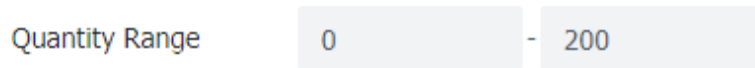
5. Set **Position Fix No**. Select the Pattern Match operator that needs to be bound. When it is running, the operator will correct the location of the ROI box according to the offset recognized by the bound pattern match operator.

Figure 9-44 Position Fix No.



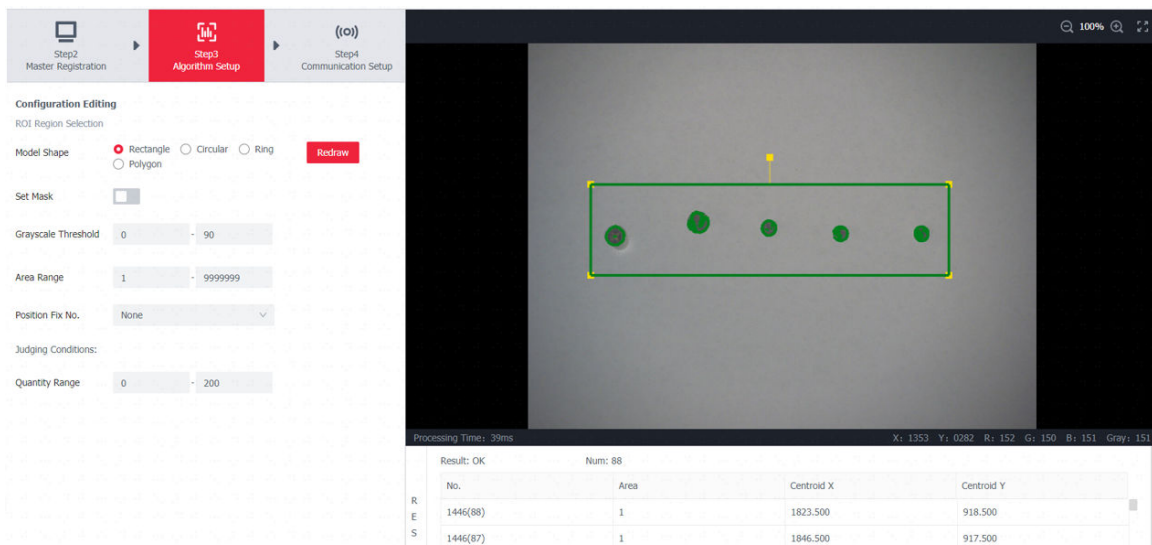
- Set **Quantity Range**. The operator status will be OK if the number of the detected blobs in the image is in the set range; otherwise, it is NG.

Figure 9-45 Quantity Range



The blobs in the image, such as noises and particles, are usually darker or lighter than the background. After setting the grayscale threshold, the area will be marked as the blob when its grayscale value is higher or lower than the set threshold, and other areas will be marked as the background. Uneven lighting or noises in the image could lead to the misjudgments. The threshold can eliminate the interferences of the area with low contrast to improve the recognition accuracy rate. We recommend you set the thresholds according to the features of the actual images, such as brightness difference.

Figure 9-46 Spot Detection



## 9.5 Measure Tools

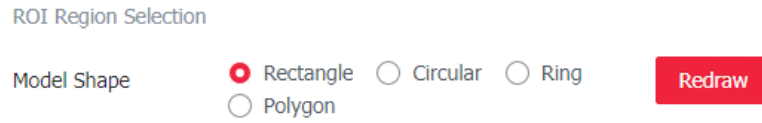
### 9.5.1 Grayscale Area

The Grayscale Area operator is for counting and selecting the pixels whose grayscale meets the set thresholds.

#### Procedure

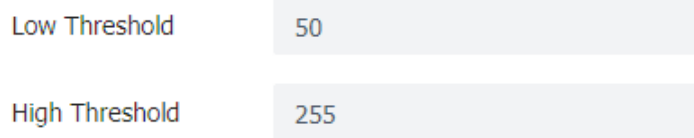
- Step 1** Draw the ROI. It supports the rectangle, circular, ring, and polygon. User can move the ROI or adjust its size.

Figure 9-47 Draw ROI



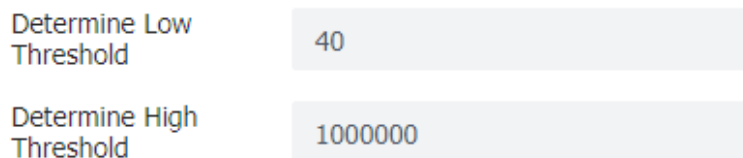
Step 2 Set the **High Threshold** and **Low Threshold**. Set the grayscale threshold of the pixels that needs to count. When the grayscale values of the pixels are in the set thresholds, the pixels can be counted. For the color sensors, the Grayscale Area operator will first convert the color image into the mono image, and then judge whether their grayscale values are in the set thresholds.

Figure 9-48 High Threshold and Low Threshold



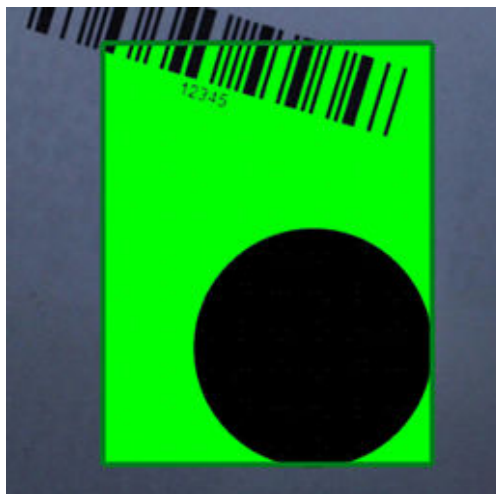
Step 3 Set the **Determine High Threshold** and **Determine Low Threshold**. The operator judges the pixels of the area that are within the grayscale thresholds whether the pixel quantity of the area is in the set quantity threshold. If it is within the set quantity threshold, the operator status will be OK; otherwise, it will be NG.

Figure 9-49 Determine High Threshold and Determine Low Threshold



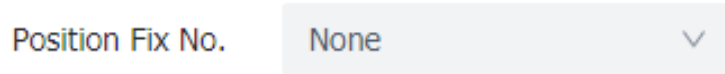
Step 4 Enable or disable the **Feature Draw**. After enabling the this function, the pixels that have been counted will turn into the green color.

Figure 9-50 Feature Draw



Step 5 Set **Position Fix No**. Select the Pattern Match operator that needs to be bound. When it is running, the operator will correct the location of the ROI box according to the offset recognized by the bound pattern match operator.

Figure 9-51 Position Fix No.

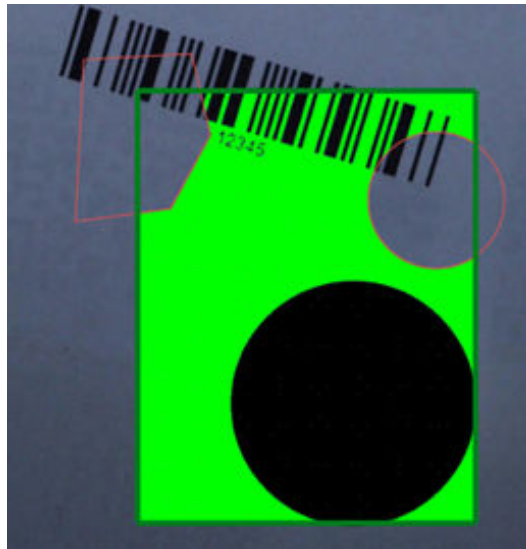


Step 6 If there are any non-detection areas needs to be shielded in the ROI area, user can enable the **Set Mask**. Select the shape to define the shielding area on the image. The shapes include rectangle, polygon, and circle. User can add and delete multiple shapes.

Figure 9-52 Set Mask



Figure 9-53 Shielding Results



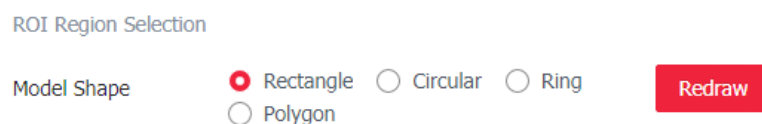
## 9.5.2 Brightness

The Brightness operator is for calculating the average brightness value in the ROI detection area to judge whether the object exists.

### Procedure

Step 1 Draw the ROI. It supports the rectangle, circular, ring, and polygon. User can move the ROI or adjust its size.

Figure 9-54 Draw ROI



Step 2 Set **Low Threshold** and **High Threshold**. The operator judges whether contrast ratio of the ROI area is in the set threshold. If it is within the set threshold, the operator status will be OK; otherwise, it will be NG.

Figure 9-55 Low Threshold and High Threshold

Low Threshold	<input type="text" value="100"/>
High Threshold	<input type="text" value="255"/>

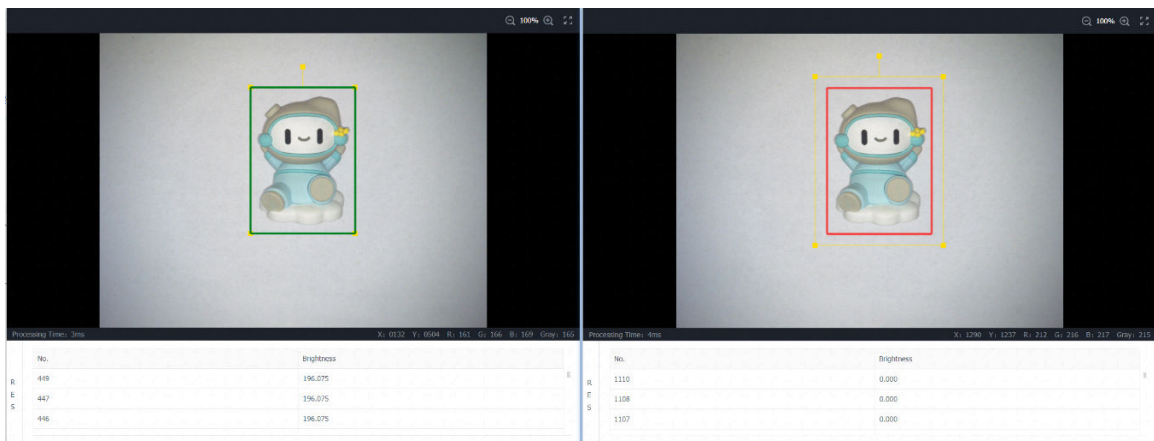
**Step 3** Set **Position Fix No.** Select the Pattern Match operator that needs to be bound. When it is running, the operator will correct the location of the ROI box according to the offset recognized by the bound pattern match operator.

Figure 9-56 Position Fix No.

Position Fix No.  ▼

**Step 4** If there are any non-detection areas needs to be shielded in the ROI area, user can enable the **Set Mask**. Select the shape to define the shielding area on the image. The shapes include rectangle and polygon. User can add and delete multiple shapes.

Figure 9-57 Set Mask



### 9.5.3 Contrast

The Contrast operator is for calculating the contrast ratio of the images in the ROI detection area, identify whether the contrast ratio of the features which need to be detected are within the set range. This operator is suitable for the image with high contrast ratio.

#### Procedure

**Step 1** Draw the ROI. It supports the rectangle, circular, ring, and polygon. User can move the ROI or adjust its size.

Figure 9-58 Draw ROI

ROI Region Selection

Model Shape  Rectangle  Circular  Ring  Polygon

Step 2 Set **Low Threshold** and **High Threshold**. The operator judges whether contrast ratio of the ROI area is in the set threshold. If it is within the set threshold, the operator status will be OK; otherwise, it will be NG.

Figure 9-59 Low Threshold and High Threshold

Low Threshold	50
High Threshold	255

Step 3 Set **Position Fix No.** Select the Pattern Match operator that needs to be bound. When it is running, the operator will correct the location of the ROI box according to the offset recognized by the bound pattern match operator.

Figure 9-60 Position Fix No.

Position Fix No.	None	▼
------------------	------	---

Step 4 If there are any non-detection areas needs to be shielded in the ROI area, user can enable the **Set Mask**. Select the shape to define the shielding area on the image. The shapes include rectangle, polygon, and circle. User can add and delete multiple shapes.

Figure 9-61 Set Mask

Set Mask	<input checked="" type="checkbox"/>	<input type="checkbox"/>	<input type="checkbox"/>	<input type="checkbox"/>	Delete
----------	-------------------------------------	--------------------------	--------------------------	--------------------------	--------

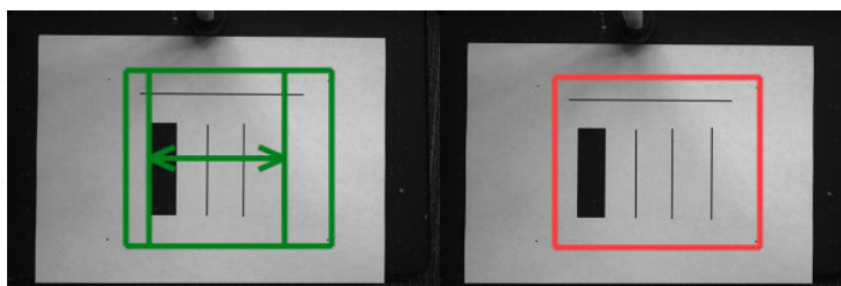
## 9.5.4 Edge Width Tool

The Edge Width Tool operator is for detecting the edges of the object in the image, and calculating the spacing between the two edges.

### Procedure

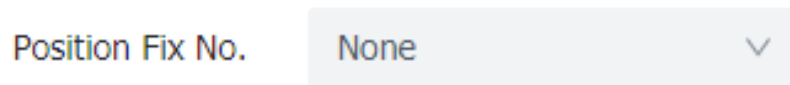
Step 1 User can drag the ROI box or adjust its size in the under-detection area according to the actual demands. When the ROI box is red, it is NG; when the ROI box is green, it is OK.

Figure 9-62 Draw ROI



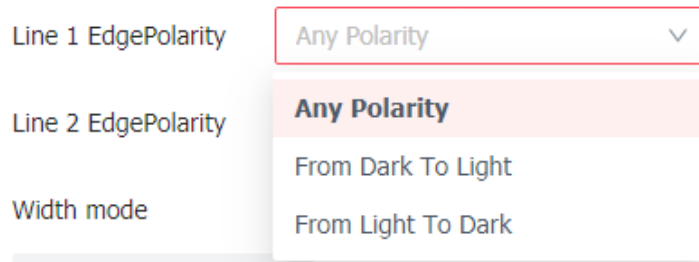
Step 2 Set **Position Fix No.** Select the Pattern Match operator that needs to be bound. When it is running, the operator will correct the location of the ROI box according to the offset recognized by the bound pattern match operator.

Figure 9-63 Position Fix No.



Step 3 Set **Line 1 Edge Polarity**. The options include From Dark to Light, From Light to Dark, any Polarity.

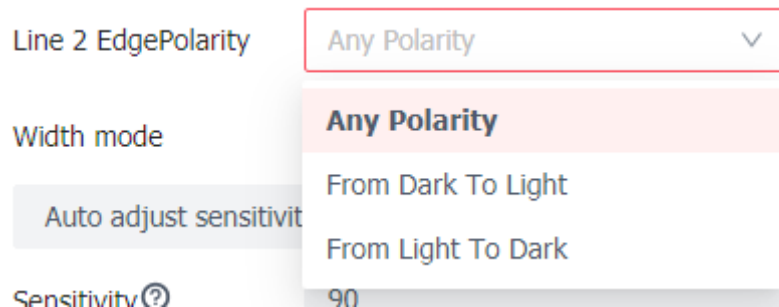
Figure 9-64 Line 1 Edge Polarity



- Any Polarity: The operator detects all types of edges regardless of the direction of the grayscale change.
- From Dark to Light: The operator only detects the edges whose grayscale changes from low to high.
- From Light to Dark: The operator only detects the edges whose grayscale changes from high to low.

Step 4 Set **Line 1 Edge Polarity**.

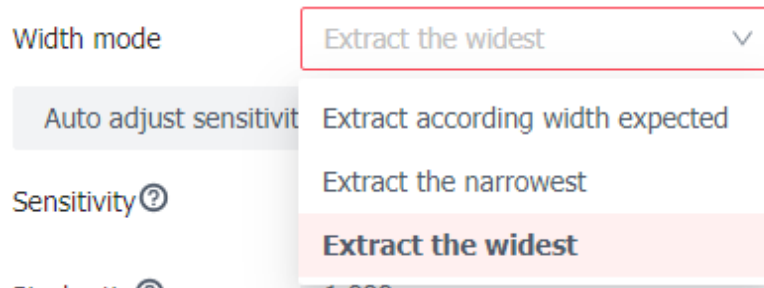
Figure 9-65 Line 2 Edge Polarity



Line 1/2 Edge Polarity: It is for defining the grayscale changing direction of the edges when detecting the edges.

Step 5 Set **Width Mode**. The options include Extract according Width Expected, Extract the Narrowest, Auto Adjust Sensitivity.

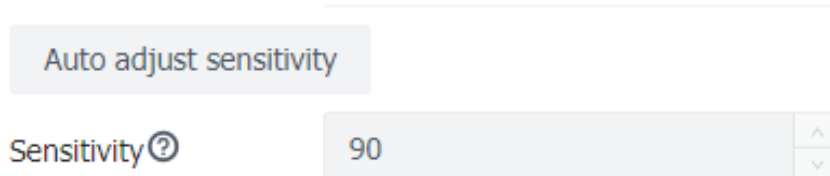
Figure 9-66 Width Mode



- **Width Mode:** This parameter is for defining how the operator selects the final results from the multiple detected width values.
- **Extract according Width Expected:** After setting this parameter, the operator will select the width value closest to the expected width value from the multiple detected width values.
- **Extract the Narrowest:** After setting this parameter, the operator will select the minimum width value from the multiple detected width values.
- **Extract the Widest:** After setting this parameter, the operator will select the maximum width value from the multiple detected width values.

Step 6 Set **Sensitivity**. The higher the value of the sensitivity, the lower the requirement to the grayscale value of the edge detection. User can manually set the value of the sensitivity, and also can click the **Auto Adjust Sensitivity**.

Figure 9-67 Auto Adjust Sensitivity

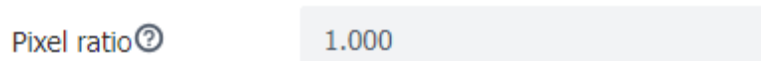


**Auto Adjust Sensitivity:** It will automatically adjust the sensitivity of the edge detection operator according to the contrast, noise level, edge clarity, etc. of the image. The adjusted sensitivity parameter is for reference only.

Step 7 Set **Pixel Ratio**. This parameter is for converting the pixel distance in the image into the actual physical distance.

- Range: 0.000~100.000

Figure 9-68 Pixel Ratio



Step 8 Set **Width Range**. This parameter is for defining the allowed measurement range of the width. The operator can filter out the measurement results which meet the requirements by setting the width range. The operator status is OK when it is within the range; otherwise, it is NG.

- Range: 1.000~9999999.999.

## 9.6 Detection Tools

The Contour Compare operator is for defect identification of the industrial components, product appearance, and objects locating in the complex environments. This operator can assist the user to complete the identification tasks in a non-contact and high-speed manner, which can significantly improve the production efficiency and quality consistency.

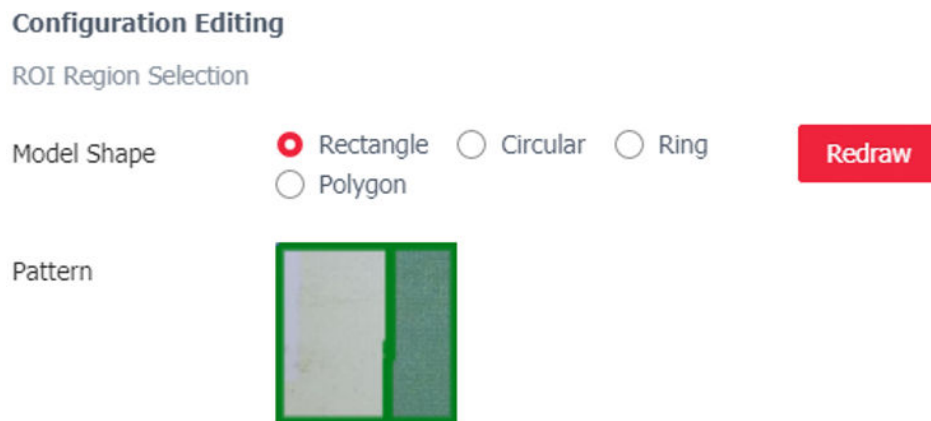
### Contour Compare

The Contour Compare operator calculates the similarity by comparing the contour features extracted from the object and reference template. The higher the score, the higher the similarity between the object features and the template.

### Procedure

1. Draw the pattern area. It supports the rectangle, circular, ring, and polygon.

Figure 9-69 Model Shape and Pattern



2. The sensitivity level includes high, medium, and low. The higher the sensitivity, the more feature points are extracted. The sensitivity level should be set according to the actual conditions, the noises could be mistakenly extracted as the feature points, and this will increase the running time of the algorithm process.

Figure 9-70 Sensitivity

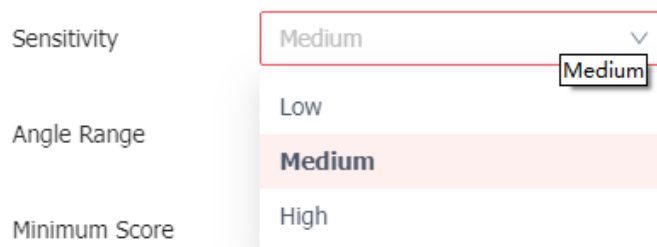
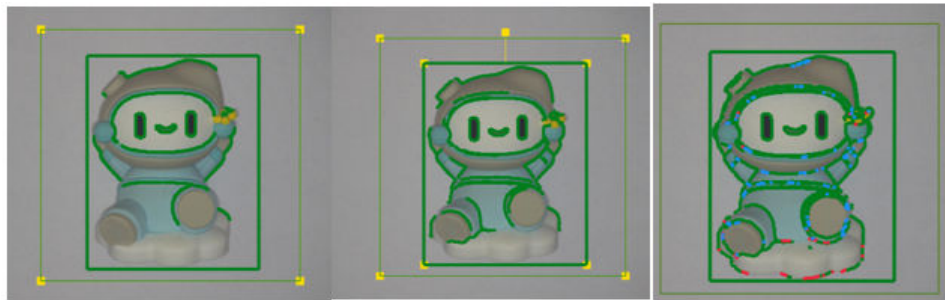
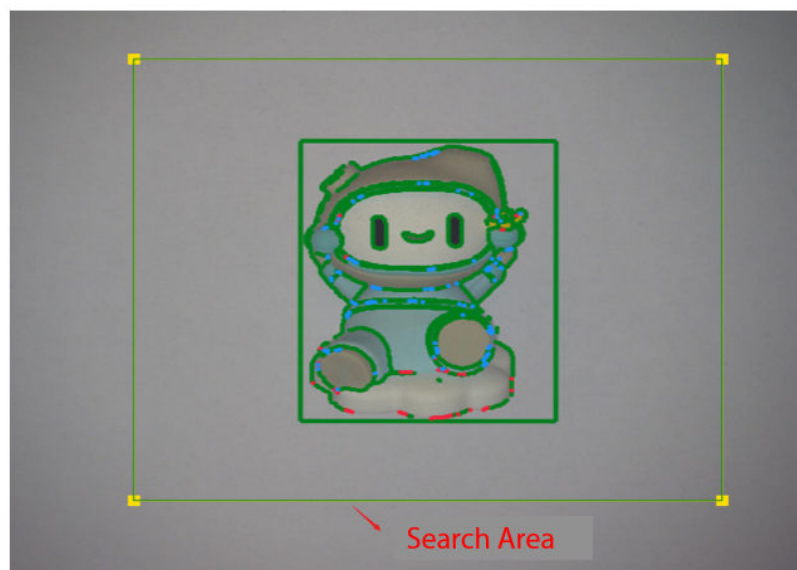


Figure 9-71 Post Processing Effect (Low/Medium/High)



3. Draw the search area. The rectangle in the figure below is the search area.

Figure 9-72 Search Area



4. Set the values of the **Angle Range**. The algorithm will recognize and match the object if its angle changing is in the set range. If the angle exceeds the set range, the algorithm cannot recognize the object. Therefore, the larger the angle range, the greater the allowable range of angle variation will be, and the longer the processing time of the algorithm is.

Figure 9-73 Angle Range



5. Set **Minimum Score**. This parameter is for setting the score threshold of the similarity between the target and the template. The higher the score, the higher the requirement to the similarity between the target and the template, which means that the object can only be recognized when the similarity score is higher than the set value.

Figure 9-74 Minimum Score



6. Set **Position Fix No.** Select the Pattern Match operator that needs to be bound. When it is running, the operator will correct the location of the ROI box according to the offset recognized by the bound pattern match operator.

Figure 9-75 Position Fix No.

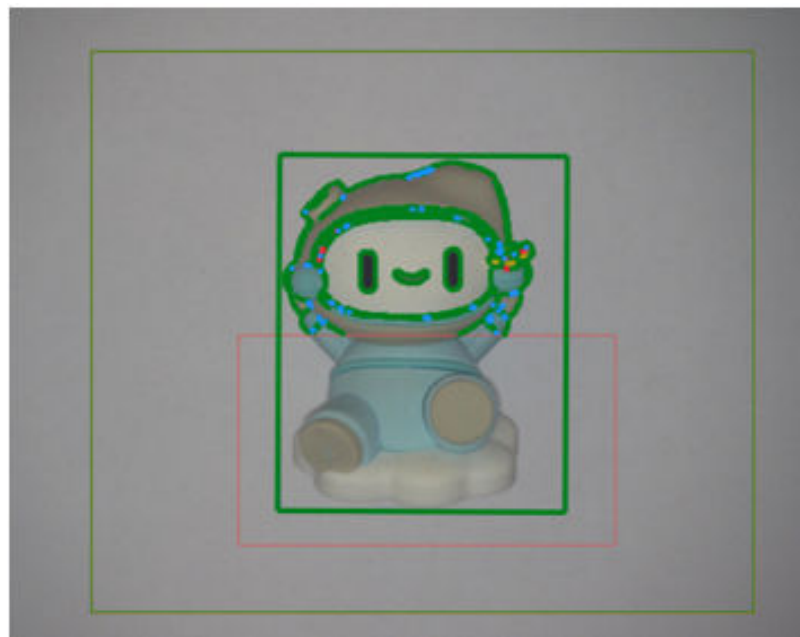


7. If there are noises in the pattern area, user can enable the **Set Mask**. Select the shape to define the shielding area on the image. The shapes include rectangle, polygon, and circle. User can add and delete the multiple shapes.

Figure 9-76 Set Mask



Figure 9-77 Shielding Results



- The sensitivity of the Contour Compare operator affects the the number of the extracted feature points. The higher the sensitivity, the more the matched feature points. Also, it will lead to the increasing of the algorithm process time. Therefore, we recommend you adjust the sensitivity according to the actual condition.
- The position correction parameter (Position Fix No.) is working based on the search area.
- This operator can detects the missing corners, collapsed edges, lamination, etc. by comparing the contours of the template image and the test image. This operator is suitable for the objects with clear boundaries and stable environments.
- The effect of the Contour Compare operator is shown in the figure below. The two images on the left are the trained template images; the two images on the right are the compared images.

Figure 9-78 Effect images of Contour Compare



## 9.7 Recognition Tools

The operators in the Recognition Tool include Data Code, Barcode, and OCR.

### 9.7.1 Data Code

The Data Code operator is for accurately locating the position of the 2D codes and decoding the contained characters. This operator can decode QR code and DM code, which are commonly used in the logistics industry and in other scenarios of 2D code recognition and decoding.

#### Procedure

Step 1 Select code type. User can select multiple code types.

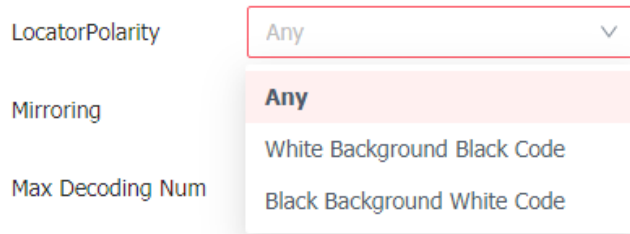
Figure 9-79 Code Category



Step 2 Set **Locator Polarity**.

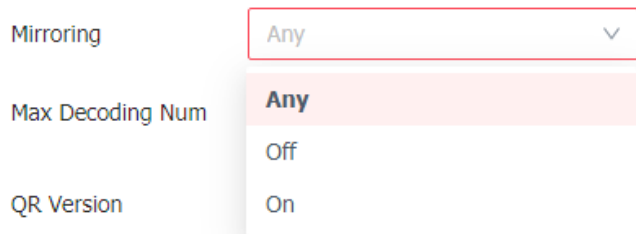
- Any: The operator will dynamically adjust the polarity of the locator according to the background color and 2D code content.
- White Background Black Code: The code background is white, and the locator and dots are black.
- Black Background White Code: The code background is black, and the locator and dots are white.

Figure 9-80 Locator Polarity



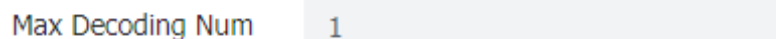
Step 3 Set **Mirroring**.

Figure 9-81 Mirroring



Step 4 Set the **Max Decoding Num**.

Figure 9-82 Max Decoding Number



**Step 5 Set QR Version/DM Version.**

Figure 9-83 QR/DM Version

QR Version	1	-	10
DM Version	1	-	24

**Step 6 Set Overtime.**

Figure 9-84 Overtime

Overtime(ms)	1000
--------------	------

**Step 7 Set Position Fix No.**

Figure 9-85 Position Fix No.

Position Fix No.	None	▼
------------------	------	---



- The more the set maximum number of the decoding, the longer the algorithm processing; therefore, we recommend you configure this parameter according to the actual demands.
- The Mirroring parameter can flip the code image along the certain axis, such as horizontal axis or vertical axis, to get the new flipped code images. The content of the flipped code image will be the same as the original.
- Timeout parameter is for defining the maximum decoding time, if the decoding time exceeds the timeout value, the decoding of the current code image will end early.

## 9.7.2 Barcode

The Barcode operator is for accurately locating the position of the barcode, and decoding the contained characters. The supported code types include code128, ean13, ean8, upca, upce, code93, code39, itf25, and codabar. These code types are commonly used in the logistics industry and for other scenarios of barcode recognition and decoding.

### Procedure

**Step 1** Select code type. User can select multiple code types.

Figure 9-86 Code Category

Code Category	<input checked="" type="checkbox"/> code128	<input type="checkbox"/> ean13	<input type="checkbox"/> ean8	<input type="checkbox"/> upca
	<input type="checkbox"/> upce	<input type="checkbox"/> code93	<input type="checkbox"/> code39	<input type="checkbox"/> itf25
	<input type="checkbox"/> codabar			



Upca code is a special code type of the ean13 code, which means that the upca code is a subset of ean13. Therefore, if the ean13 is selected, the upca code can also be detected and decoded.

**Step 2** Set **Locator Polarity**. The options include White Background Black Code and Black Background and White Code.

Figure 9-87 Locator Polarity

LocatorPolarity: White Background Black Code

Max Decoding Num: Any

Overtime(ms):

**Step 3** Set the **Max Decoding Num**.

Figure 9-88 Max Decoding Number

Max Decoding Num: 1



The more the set maximum number of the decoding, the longer the algorithm processing; therefore, we recommend you configure this parameter according to the actual demands.

**Step 4** Set **Overtime**. This parameter is for defining the maximum decoding if the decoding time exceeds the timeout value, the decoding of the current code image will end early.

Figure 9-89 Overtime

Overtime(ms): 1000

**Step 5** Enable the **ITF25 Check** and **Code39 Check**.

Figure 9-90 ITF25 Check and Code39 Check

ITF25 Check:

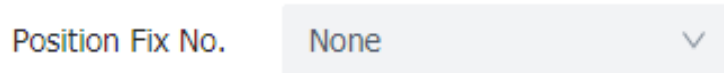
code39 Check:



- When selecting the code39 and ITF25 and disabling the code39 Check and ITF25 Check, the code verification will not be performed, and code39 and ITF25 with or without the verification code can be recognized.
- After enabling the ITF25 Check and Code39 Check, the operator will verify these two code types, and after the codes pass the verification, the operator will decode the codes.

Step 6 Set **Position Fix No.** Select the Pattern Match operator that needs to be bound. When it is running, the operator will correct the location of the ROI box according to the offset recognized by the bound pattern match operator.

Figure 9-91 Position Fix No.



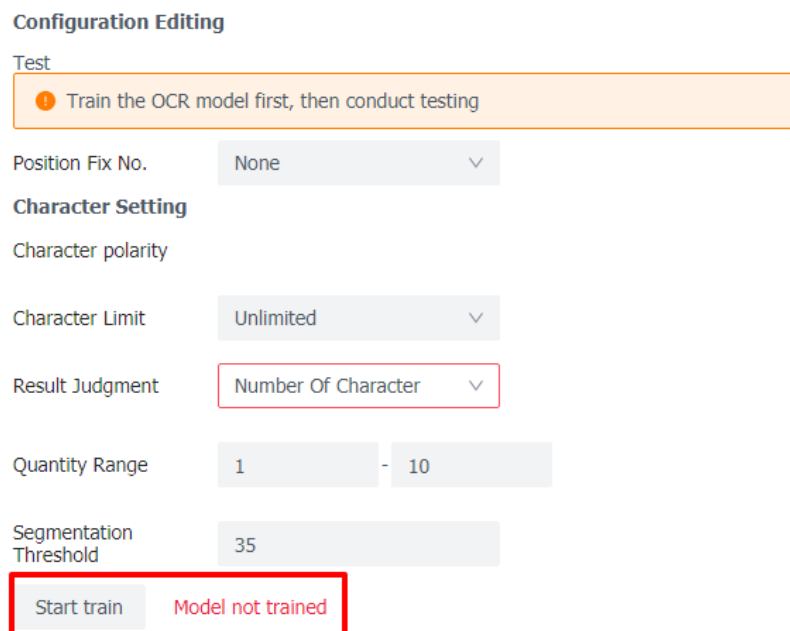
## 9.7.3 OCR (Optical Character Recognition)

The OCR operator is for extracting the characters in the detection area.

### Procedure

Step 1 Click **Start Train** to enter the **Train Config** interface.

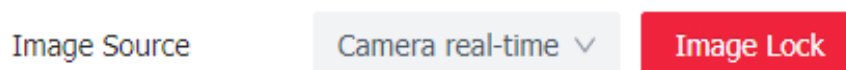
Figure 9-92 Start Train



Step 2 Set **Image Source**. The options include **Camera Real-time** and **Local Upload**.

- When selecting the **Camera Real-time**, the samples are the images acquired by sensor in real time. Click **Image Lock** to acquire an image in real time.

Figure 9-93 Camera Real-time



- When selecting the **Local Upload**, the samples are the images uploaded from the computer by user. User can select and upload multiple images. After a image is tagged, click **Next** to continue labeling.

Figure 9-94 Local Upload

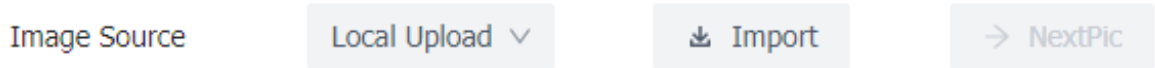


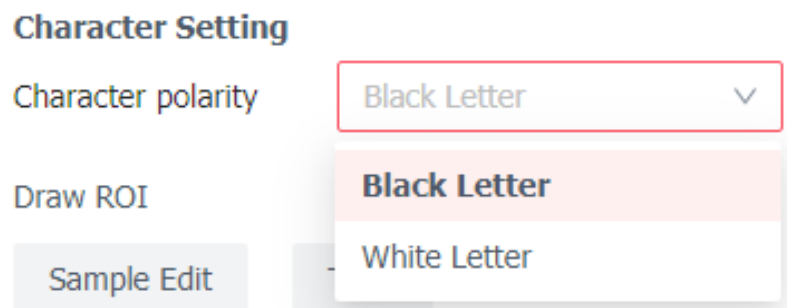
Figure 9-95 Import Image



User can only import the image whose resolution is consistent with the sensor's.

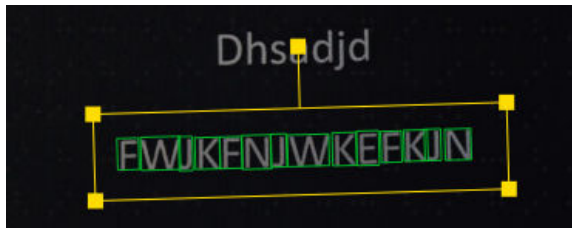
- Step 3 Set the **Character Polarity**. The options include **Black Letter** and **White Letter**. The set option of the **Character Polarity** must be consistent with the character color in the image.

Figure 9-96 Character Polarity



- Step 4 Draw ROI. Move the ROI box on the characters which need to be recognized.

Figure 9-97 Draw and Adjust the ROI



After adjusting the ROI box, click **OK**.

Figure 9-98 Click OK

Draw ROI

OK



The characters covered by the ROI box will be recognized from left to right. Therefore, if the orientation of the ROI box is not matching with the characters in the image, the recognition results will be wrong.

**Step 5**

Add tags. The operator will automatically add the tags according to the recognized characters. If there are wrong tags, user can manually modify the tags. Add: To add the ROI box on the unrecognized or mis-recognized characters to re-recognize the characters; Delete: To delete the selected mis-recognized characters in character set; Clear: To clear all the recognized characters in the character set. Next: To perform the next round of tags adding.

Figure 9-99 Add Tags

No.	Character	Number
1	1	2
2	5	2
3	6	2
4	0	1
5	2	1
6	3	1

Processing Time: 0ms X: 0000 Y: 0000 R: 000 G: 000 B: 000 Gray: 000

Character

S F 1 2 3 4 5 6

**Step 6** For the added labels, user can edit them again. Click **OK** to save the edits. Click **Cancel** to abandon all the edits.

Figure 9-100 Sample Edit

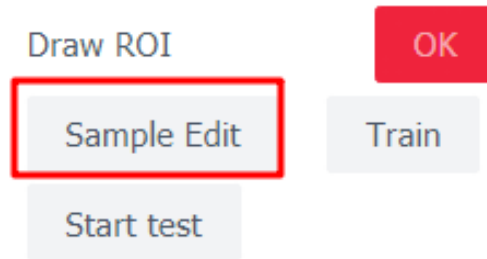
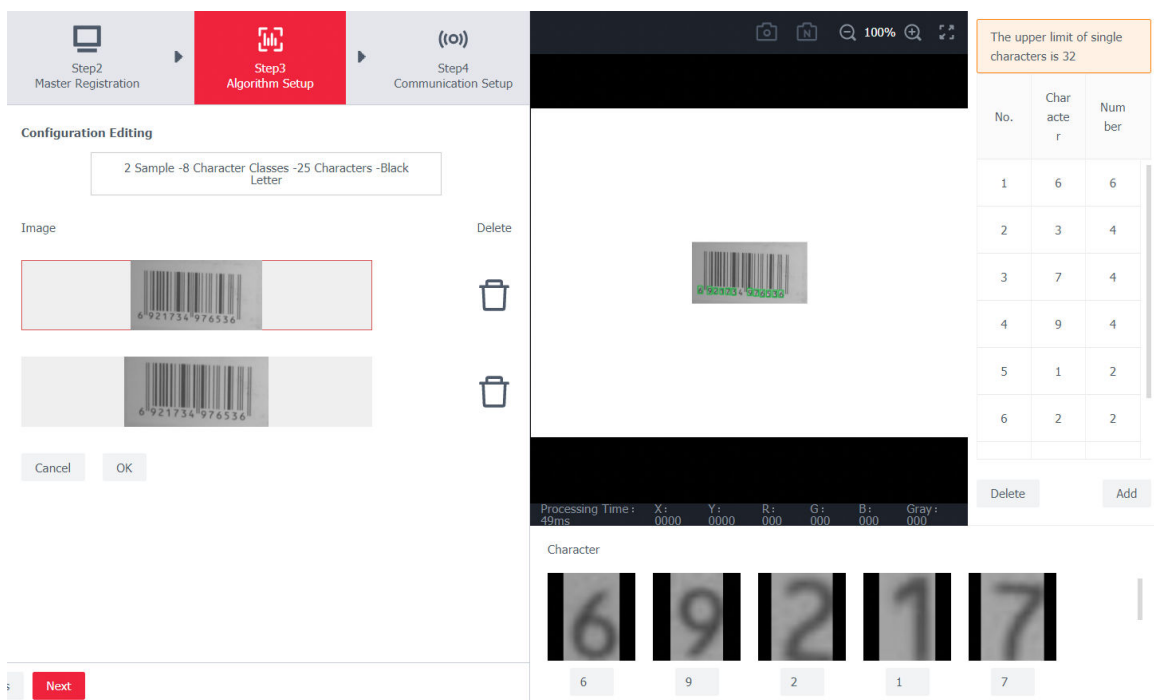


Figure 9-101 Editing Interface



**Step 7** Click **Train**. After the training is completed, the prompt box will pop up. Click **OK**.

Figure 9-102 Train

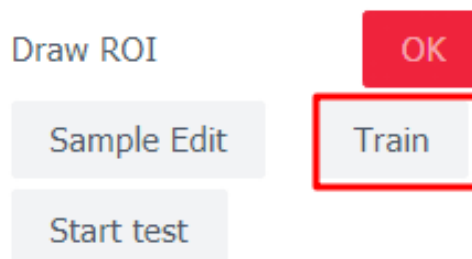
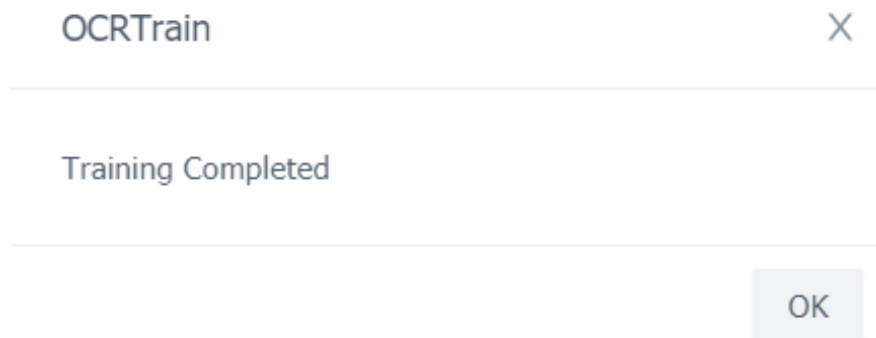
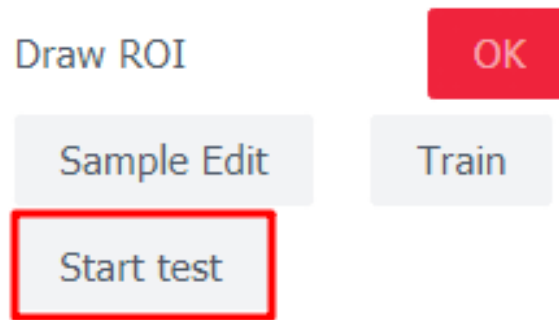


Figure 9-103 Training Completed



Step 8 Click **Start Test** to enter the **Training** interface.

Figure 9-104 Start Test



Step 9 Set **Position Fix No.** If user needs the ROI box moves with the object, the Pattern Match operator should be added. The details of Pattern Match, please refer to the **9.1 Location Tools**. Otherwise, select **None**.

Figure 9-105 Position Fix No.



Step 10 Set **Character Limit**. The options include Unlimited, Numbers Only, Uppercase Letter Only, Lowercase Letter Only, Letters Only, Number OR Letter. Select the limit type according to the actual demands. The characters which are not belong to the set type will not be outputted.

Figure 9-106 Character Limit

Character Limit: Uppercase Letters Only

Result Judgment: Unlimited

Quantity Range: Uppercase Letters Only

Segmentation Threshold: Lowercase Letters Only

Letters Only

Number OR Letter

Retrain

**Step 11** Set **Result Judgment**. The options of the Result Judgment include Number of Character, Lowest Score, and Base Character.

- Set the **Quantity Range**. When the number of the recognized characters is within the set range, the detection result will be OK; otherwise, it is NG.

Figure 9-107 Number of Character

Result Judgment: Number Of Character

Quantity Range: 1 - 10

- Set the score threshold in the **Score** after setting the **Result Judgment** to the **Lowest Score**. When the recognition score is higher than the threshold, the detection result will be **OK**; otherwise, it is **NG**.

Figure 9-108 Lowest Score

Result Judgment: Lowest Score

Score: 90

- Enter the characters in the **Base Character** after setting the **Result Judgment** to the **Base Character**. When the recognized characters are consistent with the enter characters in the **Base Character**, the detection result will be **OK**; otherwise, it is **NG**.

Figure 9-109 Base Character

Result Judgment: Base Character

Base Character

Step 12 Set **Segmentation Threshold**. When the score of the recognized characters which are covered by the ROI box is less than the set threshold, the recognized characters will be filtered out. User can increase the segmentation threshold to reduce the possibility of the mis-recognition. But the high threshold may cause that the exist characters are filtered out mistakenly. Therefore, we recommend you set the threshold according to the actual conditions.

Figure 9-110 Segmentation Threshold

Step 13 Click **Retrain** when the recognition result is not satisfying.

Figure 9-111 Retrain



The textures in the background may be mis-identified as the characters. Therefore, please ensure that the background of the image is simple and clear.

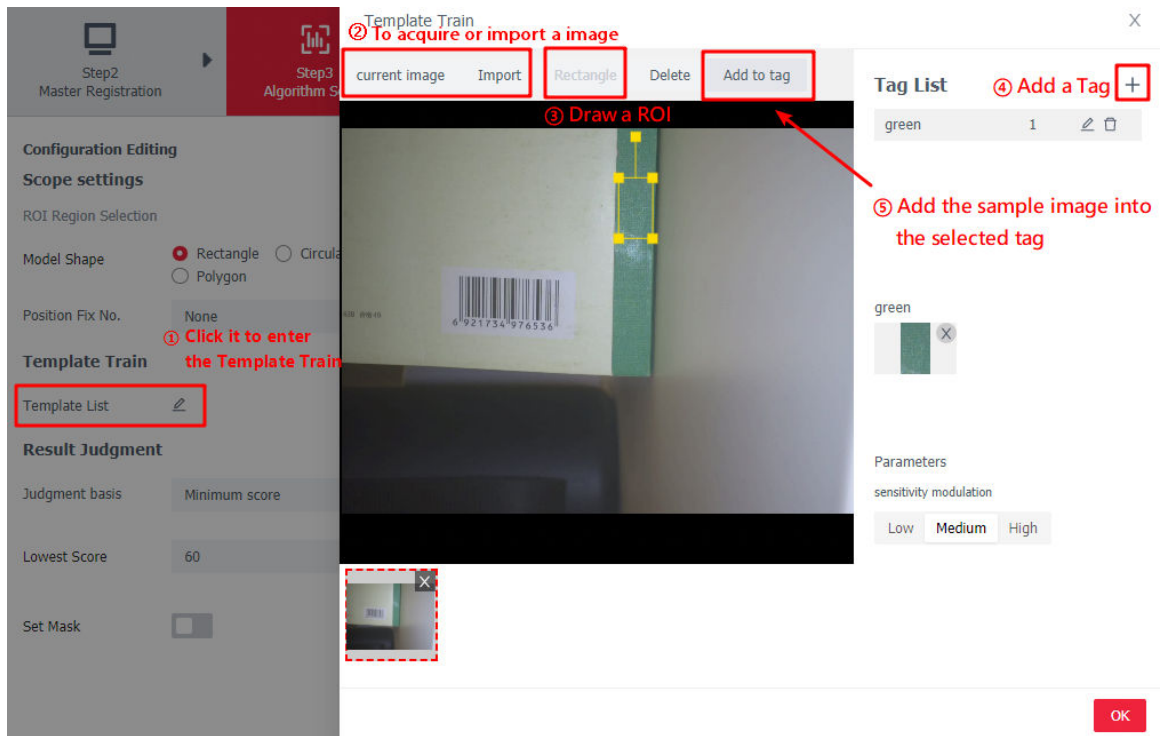
## 9.7.4 Color Recognition

The Color Recognition operator is for matching and recognizing the colors. The operator extracts the colors from the ROI area and trains the color template. The color recognition is performed by calculating the similarity between the colors of objects and color template. This operator is only available for the color sensor.

### Procedure

Step 1 Train the template of the color recognition. Click the icon on the right side of the **Template List** to enter the **Template Train** interface. User can use the current image or import image to train the template. First, click the + to add the color tag into the **Tag List** which is on the right side of the **Template Train** interface. Then, click **Rectangle** to draw the ROI box.

Figure 9-112 Add Color Tag



**Step 2** Move the ROI box and adjust its size. Then, click the **Add to Tag** to add image selected by the ROI into the specified color tag. User can modify and delete the images stored in the color tag and tag name. The sensitivity levels of the color recognition include Low, Medium, and High. After selecting the level, click **OK** to start the color template training.

Figure 9-113 Tag and Training

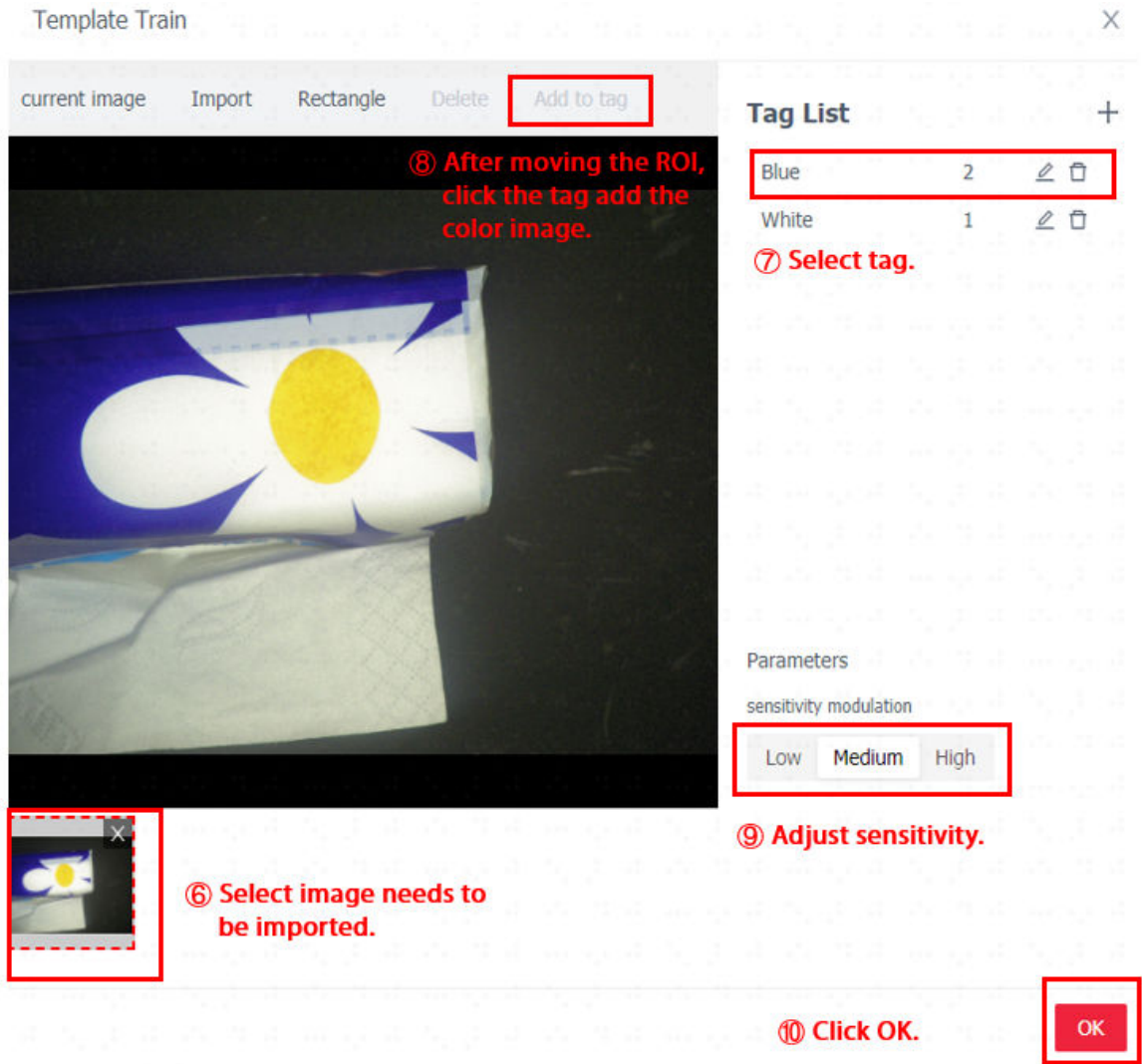
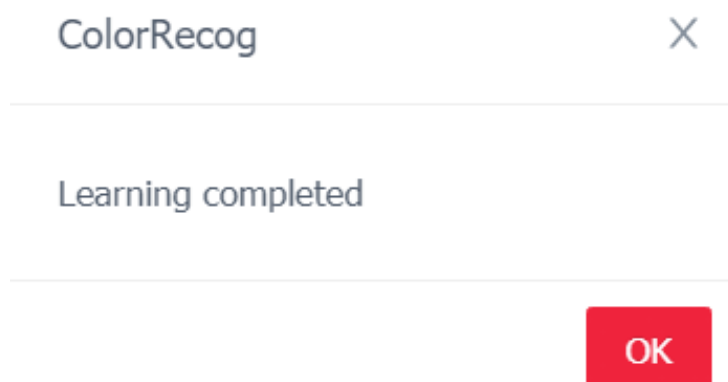
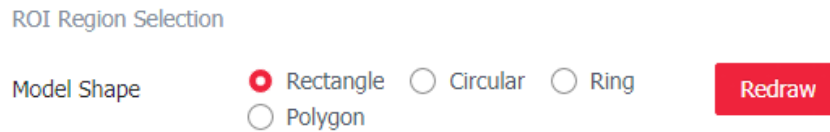


Figure 9-114 Learning Completed



**Step 3** Draw the ROI. It supports the rectangle, circular, ring, and polygon. User can move the ROI or adjust its size.

Figure 9-115 Draw ROI



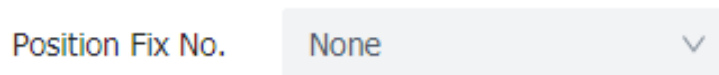
Step 4 If there are any non-detection areas needs to be shielded in the ROI area, user can enable the **Set Mask**. Select the shape to define the shielding area on the image. The shapes include rectangle and polygon. User can add and delete multiple shapes.

Figure 9-116 Set Mask



Step 5 Set **Position Fix No.** Select the Pattern Match operator that needs to be bound. When it is running, the operator will correct the location of the ROI box according to the offset recognized by the bound pattern match operator.

Figure 9-117 Position Fix No.

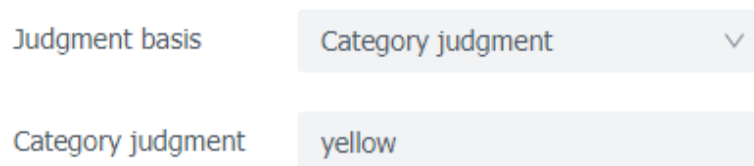


Step 6 Set **Judgment Basis**. The options include the **Minimum Score** and **Category**. After selecting the Minimum Score, if the recognition score is higher than the set minimum score, the operator status will be OK; otherwise, it is NG. After selecting the **Category**, when the recognition tag on the ROI box is consistent with the tag entered in the **Category Judgment**, the operator status will be **OK**; otherwise, it is **NG**.

Figure 9-118 Minimum Score



Figure 9-119 Category



## 9.8 Logic Tools

The operators in the Logic Tools include Logic Check, Condition Check, Mathematical, String Comparison. These operators are mainly working based on the logic operation.

## 9.8.1 Logic Check

During the running of the operators, user can use the Logic Check operator to judge the running statuses of the operators, and execute the corresponding operations according to the judgment results.

### Procedure

Step 1 Set **Operation Type**.

Figure 9-120 Operation Type

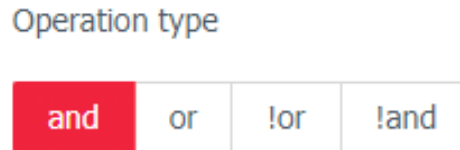
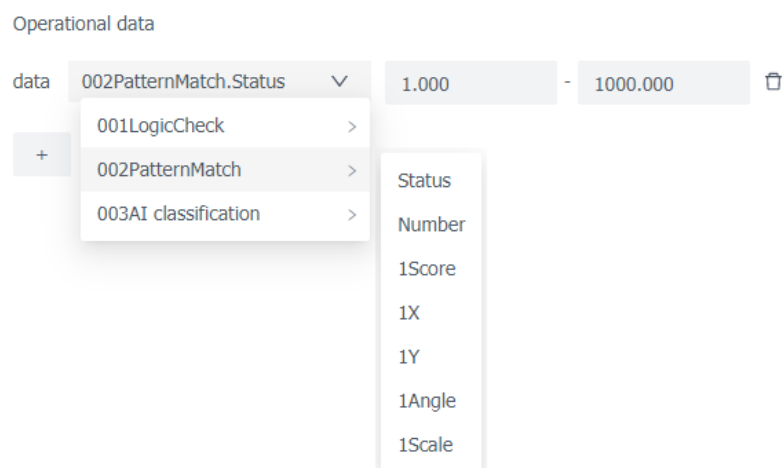


Table 9-1 Operation Type Description

Name	Description
And	The operation result is True when all the conditions are True. The operator status is OK when the operation is True; otherwise, it is NG.
Or	The operation result is True when at least one condition is True. The operator status is OK when the operation result is True; otherwise, it is NG.
!Or	The operation result is True when all conditions are False. The operator status is OK when the operation result is True; otherwise, it is NG.
!And	The operation result is True when at least one condition is False. The operator status is OK when the operation result is True; otherwise, it is NG.

Step 2 Set **Operational Data**. Click + to add the operational data.

Figure 9-121 Operational Data



The Logic Check operator is for performing the logic operation to the running status of the operator. User can add multiple running statuses of operators in the Operational Data. When the operator status is 1, it refers to the OK; when the operator status is 0, it refers to the NG.

## 9.8.2 Condition Check

The Condition Check operator is for judging whether the output results of the single operator or multiple operators meets the requirements of the set conditions.

### Procedure

Step 1 Set **Operation Type**.

Figure 9-122 Operation Type

### Configuration Editing

#### Operation type



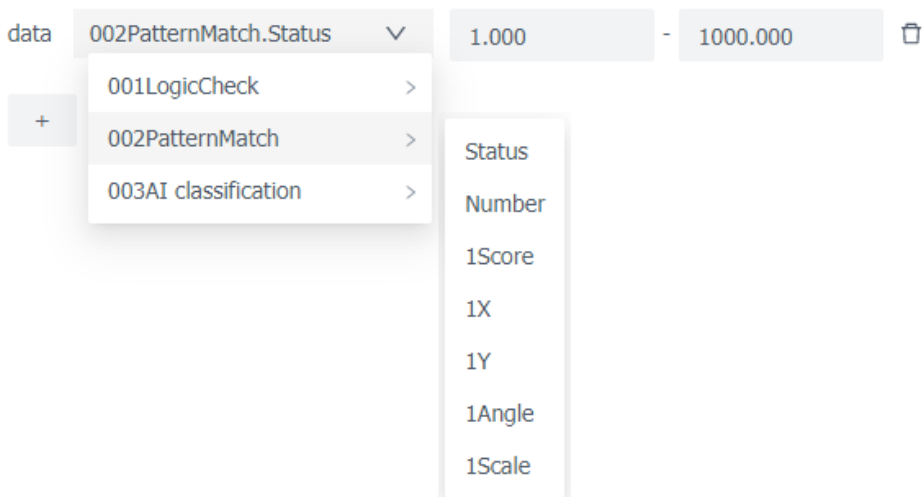
- All Comply: When the output results of all operators meet the set conditions, the running status of the project is OK; otherwise, it is NG.
- Any Compliance: When the output result of any operator meets the set condition, the running status of the project is OK; otherwise, it is NG.

Step 2 Set **Operational Data**. Click + to add the data, click **Select** in the added data to select the operator and its information type, and set the judgment condition.

- Range: 1.000~1000.000

Figure 9-123 Operational Data

#### Operational data



The Condition Check operator is for judging the output result of the operator. When setting the operational data, user can add multiple information types of one operator. When the operator status is 1, it refers to the OK; When the operator status is 0, it refers to the NG.

## 9.8.3 Mathematical

The Mathematical operator can use the output data of the operators as the variables. Also, user can enter the expressions to perform the mathematical operations. The operation results can be sent by communication.

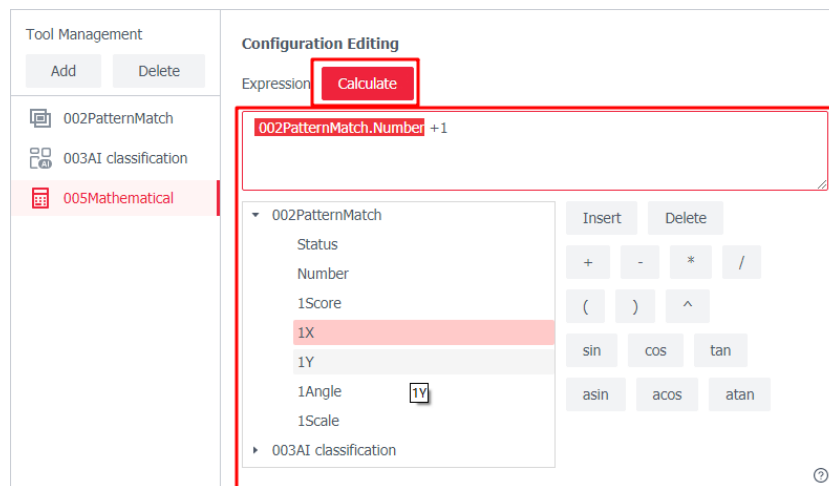
### Procedure

- Step 1 Write the arithmetic expressions.
1. Select the output item of operator that needs to be operated.
  2. Click **Insert** to insert the expression of the output item of the selected operator.



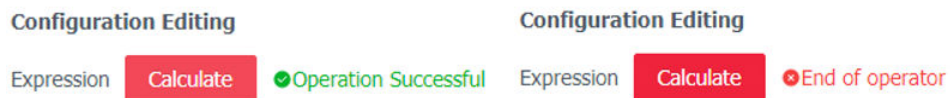
User can edit or delete the entered mathematic expressions in the input box. Select the expression completely in the input box, and click **Delete** to delete it.

Figure 9-124 Input Expressions



3. Select the proper sign of the operation.
4. Click **Calculate** to perform the operation.

Figure 9-125 Arithmetic Results



There are two error types of the mathematical operation.

- **Illegal Mathematical Operation:** It includes but not limited to the divisor is 0, the input field of inverse trigonometric function is not in [-1,1]. The operation will work after clicking the Calculate, but the operator status is NG.
- **Expression Does Not Meet the Standards:** It includes but not limited to the operation sign exists at the beginning or end of the expression, unrecognized signs, and unpaired parentheses. At this time, the operation will not work.

- Step 2 Click **Calculate** to start the arithmetic. It adopts the the float type variables by default, and the result can be output in the **Communication Setup**.



Since the arithmetic adopts the float type variables, the number of significant digits in the output result is 6. Furthermore, for the integers whose absolute value exceeds 16777215, the operator status is NG because the float type variables cannot accurately illustrate it.

## 9.8.4 String Comparison

The String Comparison operator is for comparing the subscription value and comparison value. If the comparison result meets the judgment condition, it is OK; otherwise, it is NG.

### Procedure

**Step 1** Select the output item of the operator by setting the subscription condition.

Figure 9-126 Subscription Condition

The screenshot shows the configuration editing interface for the String Comparison operator. On the left, under 'Tool Management', there are 'Add' and 'Delete' buttons. Below them, a list of operators is shown: 'A|a 001StringComparison', '004DataCode', and '005BarCode'. The '004DataCode' and '005BarCode' items are highlighted with a red box. On the right, under 'Configuration Editing', the 'Subscription Condition' dropdown is open, showing a list of items: '004DataCode' and '005BarCode'. The 'Comparison Value' field shows '004DataCode' and '005BarCode' with corresponding dropdowns for '1CodeType' and '1Data'. The 'Result Judgment' section has 'Meet as OK' selected.

**Step 2** Set **Comparison Method** and **Subscription Condition**. The options include Subscribe, Fixed String, and Regular Expression.

- After setting the **Comparison Method** to the **Subscribe**, select the output item of the other operators in the **Subscription Condition** as the comparison item.

Figure 9-127 Subscription Condition

The screenshot shows the configuration editing interface for the String Comparison operator. On the left, under 'Tool Management', there are 'Add' and 'Delete' buttons. Below them, a list of operators is shown: 'A|a 001StringComparison', '004DataCode', and '005BarCode'. The '004DataCode' and '005BarCode' items are highlighted with a red box. On the right, under 'Configuration Editing', the 'Subscription Condition' dropdown is set to '004DataCode.1CodeType'. The 'Comparison Method' dropdown is set to 'Subscribe'. The 'Subscription Condition' dropdown is open, showing a list of items: '004DataCode' and '005BarCode'. The 'Result Judgment' section has 'Meet as OK' selected.

- After setting the **Comparison Method** to the **Fixed String**, the entered strings will be as the comparison value.

Figure 9-128 Fixed String

**Comparison Value**

Comparison Method

Fixed String

- When setting the **Comparison Method** to the **Regular Expression**, the entered expression in the **Regular Expression** will be as the comparison rule.

Figure 9-129 Regular Expression

**Comparison Value**

Comparison Method

Regular Expression  ?



The regular expression does not support the \u keywords, which refers to the Unicode-encoded characters.

Step 3 Select the condition of the result judgment standard in the **Result Judgment**. The options include **Meet as OK** and **Not Meet as OK**.

- After selecting the **Meet as OK**, the judgment result is OK when the subscription value equals to the comparison value.
- After selecting the **Not Meet as OK**, the judgment result is OK when the subscription value does not equal to the comparison value.

Figure 9-130 Result Judgment

### Result Judgment

Meet as OK  Not Meet as OK

# 10 Communication Protocol Document

The EasyVS supports the multiple communication methods, including TCP Client, TCP Server, UDP, Profinet, EtherNet/IP, Modbus TCP, UART, FTP. User can click Help to find the help documents of communication protocol settings.

Figure 10-1 Help

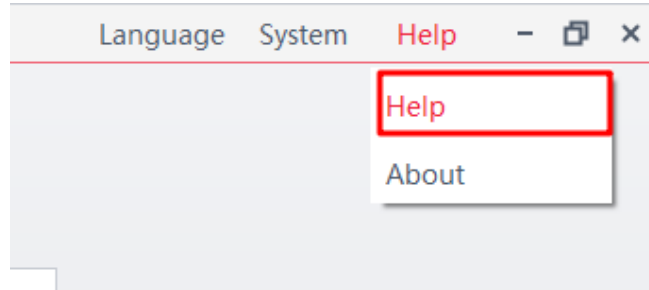


Figure 10-2 Help Documents

Name	Time	Type	Size
Folder EtherNetIP	2025/6/11 11:20		
Folder FTP	2025/6/11 11:20		
Folder PROFINET	2025/6/11 11:20		
Folder Serial Port	2025/6/11 11:20		
Folder TCP Client	2025/6/11 11:20		
Folder TCP Server	2025/6/11 11:20		
Folder UDP	2025/6/11 11:20		

# 11 FAQ

## 11.1 Client Cannot Find Sensor

### Possible Reasons

- Sensor are not started normally, and the power supply cannot meet the requirements.
- Abnormal network cable connection.
- The sensor and the client are not under the same network segment.
- Firewall forbidden the network access.
- IP Conflict: The IP address of sensor conflicts with the PC's or other devices.

### Solutions

- Power Supply: Make sure that the power supply and cable are suitable.
- Network Connection: Check the indicator of the sensor, and make sure the network connection is normal. Also, make sure the device and client are on the same network segment.
- Disable the firewall, or add the client software into the allow-list.

## 11.2 Sensor Disconnection

### Possible Reasons

- Hardware problems, such as poor contact of network card and network cable.
- Unmatched configurations of network adapter and sensor.

### Solutions

- Perform cross verification for hardware, if failure happens, replace the corresponding hardware.
- Check the NIC configuration.

## 11.3 Algorithm Processing Does Not Meet Expectations

### Possible Reasons

- Image FOV or illumination does not meet the requirements.
- Improper parameter configurations.

### Solutions

- Check the parameters of sensor FoV and the illumination. Review the sensor parameters, such as trigger mode, trigger delay, exposure and gain, illumination, etc.
- Check the parameters of the algorithm, especially the ROI box, polarity, filtering conditions, etc.

## 11.4 External Trigger Cannot be Enabled

### Possible Reasons

- Incorrect cable connection of external trigger.
- The trigger mode is not set to external trigger.

### Solutions

- Select the required trigger mode and make sure that the external cable connection is correct.

## 11.5 Unable to Login the Web Client

### Possible Reasons

- The IP address of the sensor was not defined which means it is the private IP address.
- IP address of the sensor was changed.

### Solutions

- Use EasyVS to find sensor and check its IP address, and then use the correct IP address to log in the web client.